

FP10 Steel Facing

VA10-FL06 **VA10-FL39**
BLACK PAINTED *BRUSHED NICKEL*
PLATED

Warning

The plating of the facing should never come in contact with masonry product such as mortar, acid or any other products containing abrasives. Damages and discolouration caused by these products will void the warranty.

This facing assembly contains the following part:

1. Steel facing already assembled (1X)

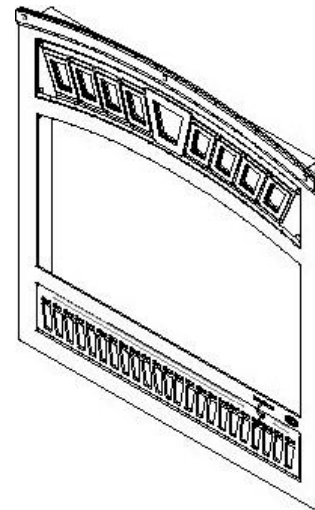

Installing procedure for the steel facing :

1. Lean the faceplate on the front of the fireplace.

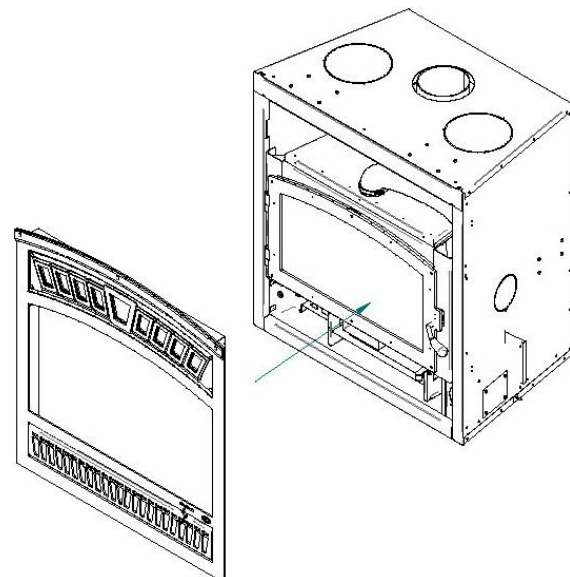

2. Lower the bottom louver.

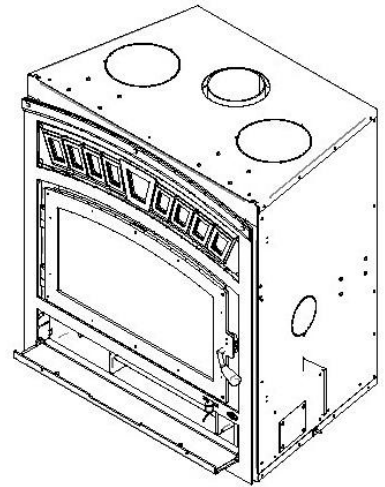

3. Fasten the fireplace springs on the faceplate in order to hold it.

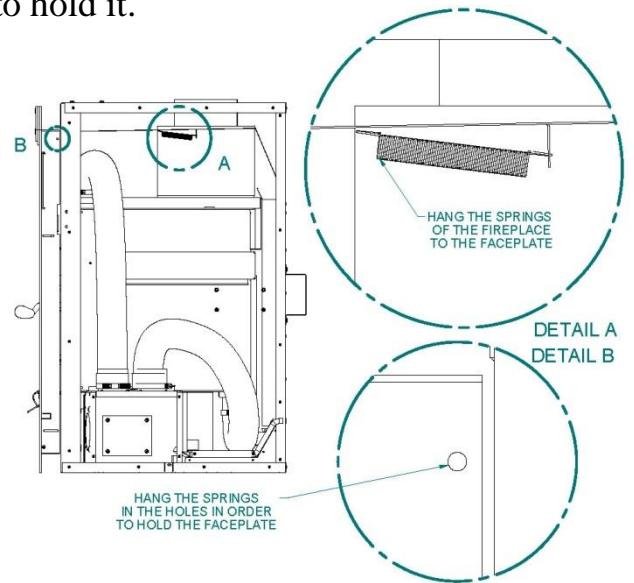

4. Firmly push the faceplate to the fireplace in order to secure the bottom.

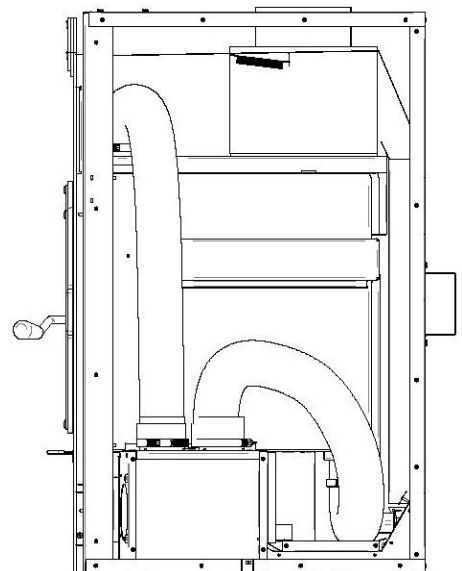

5. Secure the faceplate using the two self-tapping screws provided with the owner's manual.

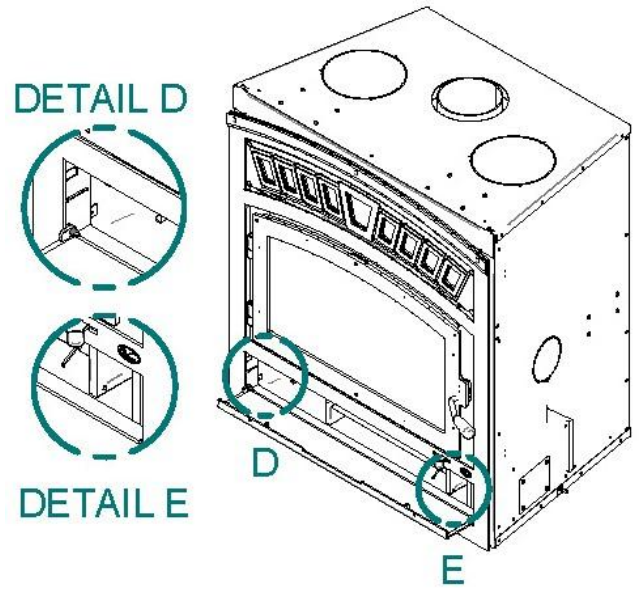

6. Fix the springs of the bottom of the faceplate to the washers on the louver.

