

Valcourt

The Fireplace of Your Dreams

Installation and Operation Manual



Safety tested according to
ULC S610 and UL 127
by an accredited laboratory

Stove Builder International Inc.
250, rue de Copenhague,
St-Augustin-de-Desmoures (Quebec)
Canada G3A 2H3
After-sale service: 418-908-8002
E-mail: tech@sbi-international.com

www.valcourtinc.com

READ AND KEEP THIS MANUAL FOR REFERENCE



This manual is available for free download on the manufacturer's web site. It is a copyrighted document. Re-sale is strictly prohibited. The manufacturer may update this manual from time to time and cannot be responsible for problems, injuries, or damages arising out of the use of information contained in any manual obtained from unauthorized sources.

45530A
16-02-2016
Printed in Canada

THANK YOU FOR CHOOSING THIS VALCOURT FIREPLACE

As one of North America's largest and most respected wood stove and fireplace manufacturers, VALCOURT takes pride in the quality and performance of all its products. We want to help you get maximum satisfaction as you use this product.

In the pages that follow you will find general advice on wood heating, detailed instructions for safe and effective installation, and guidance on how to get the best performance from this fireplace as you build and maintain fires, and maintain your wood heating system.

Congratulations on making a wise purchase.

Read this entire manual before you install and use your new fireplace. It is important that you follow the installations guidelines exactly. Failure to install this fireplace correctly could result in a house fire, bodily injury or even death.

You may need to obtain a building permit for the installation of this fireplace and the chimney that it is connected to. Consult your municipal building or fire department about installation requirements in your area. We recommend that you also inform your home insurance company to find out if the installation will affect your policy.

REGISTER YOUR WARRANTY ONLINE

To receive full warranty coverage, you will need to show evidence of the date you purchased your unit. Keep your sales invoice. We also recommend that you register your warranty online at

<http://www.valcourtinc.com/en/service-support/warranty-registration>

Registering your warranty online will help us track rapidly the information we need on your unit.

PLEASE NOTE THAT THE PICTURES SHOWN IN THIS MANUAL ARE GENERIC AND MAY NOT MATCH EXACTLY THE LOOK OF YOUR FIREPLACE.

CAUTION: DO NOT ATTEMPT TO MODIFY OR ALTER THE CONSTRUCTION OF THE FIREPLACE OR ITS COMPONENTS. ANY MODIFICATION OR ALTERATION OF CONSTRUCTION MAY VOID THE WARRANTY, LISTINGS AND APPROVALS OF THIS SYSTEM. IN THAT CASE, STOVE BUILDER INTERNATIONAL (SBI) WILL NOT BE RESPONSIBLE FOR DAMAGES. INSTALL THE FIREPLACE ONLY AS DESCRIBED IN THESE INSTRUCTIONS.

PART A – INSTALLATION	5
1.0 Safety Information	5
1.1 Regulations Covering Fireplace Installation	6
2.0 General Information	6
2.1 FP7LM Antoinette Wood Fireplace Specifications	6
2.2 The Benefits of EPA Voluntary Emission Program «Low Mass» Phase II	7
3.0 Fireplace Installation	7
3.1 Installation of Spacers and Heat Shield	8
3.1.1 Spacers	8
3.2 Fire Baffles Installation	9
3.3 Locating the FP7LM Antoinette Wood Fireplace	11
3.4 Heart Extension Requirements	12
3.5 Framing, Facing, Mantel, and Combustible Shelf	13
3.5.1 Framing	13
3.5.2 Facing	21
3.6.3 Combustible Shelf	24
3.6 Fresh Air Kit	27
3.6.1 Fresh Air kit Installation	27
3.7 Faceplate Installation (Sold Separately)	29
3.7.1 Narrow Overlap	29
3.7.2 Masonry Trim	30
3.8 Door Alignment	31
4.0 Venting System (Chimney and Chimney Connector).....	32
4.1 General	32
4.2 Suitable Chimneys	33
4.3 Chimney Installation Notes	35
4.4 Chimney Installation Instructions	38
4.6 Angled Radiation Shield	42
4.7 Chimney Support Installation	42
4.7.1 Universal Roof Support	42
4.7.2 Universal Offset Support	43
4.8 Chimney Chase and Multiple Terminations	43
4.9 Installation Instructions for Masonry Application	44
PART B - OPERATION AND MAINTENANCE	45
5.0 Fuel	45
5.1 The Use of Manufactured Logs	45
6.0 OPERATING THE FP7LM ANTOINETTE WOOD FIREPLACE.....	46
6.1 First Fires	46
6.2 Building a Fire	46
6.3 Maintaining the Fire	47
6.4 Air Intake Control and Exhaust Damper	48
6.5 Smoking – Causes and Troubleshooting	48

A.	Closed exhaust damper	48
B.	Negative pressure in the house	49
C.	Wet wood.....	49
D.	Dirty or blocked chimney	49
E.	Chimney not long enough.....	49
F.	Poor chimney draft	49
7.0	MAINTAINING YOUR FP7LM ANTOINETTE WOOD FIREPLACE	50
7.1	Creosote – Formation and Need for Removal	50
7.2	Chimney Maintenance	50
7.3	Fire Baffles Removal Prior to Cleaning the Chimney	50
7.4	Dealing With a Chimney Fire	51
7.5	Disposal of Ashes	52
7.6	Refractory Panels Replacement	52
7.7	Glass Care – Replacement	54
7.8	Glass Care – Cleaning	55
8.0	VIEWS WITH MEASUREMENTS.....	56
8.1	EXPLODED DIAGRAM AND PARTS LIST	58
	VALCOURT LIMITED LIFETIME WARRANTY	60

PART A – INSTALLATION

1.0 Safety Information

CAUTION: THE INFORMATION GIVEN ON THE CERTIFICATION LABEL AFFIXED TO THE APPLIANCE ALWAYS OVERRIDES THE INFORMATION PUBLISHED, IN ANY OTHER MEDIA (OWNER’S MANUAL, CATALOGUES, FLYERS, MAGAZINES AND/OR WEB SITES).

CAUTION: NEVER USE GASOLINE, GASOLINE-TYPE LANTERN FUEL, KEROSENE, CHARCOAL LIGHTER FLUID OR SIMILAR LIQUIDS TO START OR “FRESHEN UP” A FIRE IN THIS FIREPLACE. KEEP ALL SUCH LIQUIDS WELL AWAY FROM THE FIREPLACE AT ALL TIMES.

CAUTION: KEEP COMBUSTIBLE MATERIALS AT LEAST 48 INCHES AWAY FROM THE FRONT OF THE FIREPLACE OPENING.

CAUTION: NEVER LEAVE CHILDREN UNATTENDED WHEN THERE IS A FIRE BURNING IN THE FIREPLACE.

CAUTION: NEVER USE GRATE OR ELEVATE FIRE. BUILD WOOD FIRE DIRECTLY ON HEARTH.

CAUTION: DO NOT USE A FIREPLACE INSERT AND OTHER PRODUCTS NOT SPECIFIED FOR USE WITH THIS FIREPLACE.

CAUTION: DO NOT OBSTRUCT AIR INTLETS. THIS FIREPLACE NEEDS AIR FOR ITS GOOD OPERATION.

WARNING: THIS FIREPLACE IS NOT CERTIFIED FOR USE WITH A GAS LOG LIGHTER. SUCH A DEVICE SHOULD THEREFORE NOT BE INSTALLED ON THE FIREPLACE.

WARNING: THIS FIREPLACE HAS NOT BEEN TESTED WITH A VENTED OR UNVENTED GAS LOG SET. TO REDUCE RISK OF FIRE OR INJURY, DO NOT INSTALL A VENTED OR UNVENTED GAS LOG SET INTO THIS FIREPLACE.

WARNING: DO NOT USE MATERIAL OTHER THAN THOSE LISTED IN THE REPLACEMENT PARTS SECTION DURING INSTALLATION AS THEY MAY BE SAFETY HAZARDS AND A FIRE COULD RESULT.

WARNING: DO NOT INSTALL THIS FIREPLACE IN A MOBILE HOME.

CAUTION: FOR SAFETY REASONS, IT IS VERY IMPORTANT TO USE A NON-COMBUSTIBLE MATERIAL FOR THE SURROUND OF THE FIREPLACE. IN THAT CASE, A CEMENT-BOARD (DUROCK STYLE) IS MANDATORY. FAILING TO RESPECT THIS GUIDELINE MAY RESULT IN A FIRE.

CAUTION: THIS HEATING UNIT MUST SERVE AS A SUPPLEMENTARY HEAT SOURCE. AN ALTERNATIVE HEAT SOURCE SHOULD BE AVAILABLE IN THE HOME IF NEEDED. THE MANUFACTURER CANNOT BE RESPONSIBLE FOR ADDITIONAL HEATING COSTS ASSOCIATED WITH THE USE OF AN ALTERNATIVE HEAT SOURCE. IT IS HIGHLY RECOMMENDED THAT THE USER BUYS THIS PRODUCT FROM A RETAILER WHO CAN PROVIDE INSTALLATION AND MAINTENANCE ADVICES.

1.1 Regulations Covering Fireplace Installation

When installed and operated as described in these instructions, the FP7LM Antoinette wood fireplace is suitable for use as a fireplace appliance in residential installations.

In Canada, the CSA B365 Installation Code for Solid Fuel Burning Appliances and Equipment and the CSA C22.1 Canadian National Electrical Code are to be followed in the absence of local code requirements. In the USA, the NFPA 211 Standard for Chimneys, Fireplaces, Vents and Solid Fuel-Burning Appliances and the ANSI NFPA 70 National Electrical Code are to be followed in the absence of local code requirements.

We recommend that our woodburning hearth products be installed and serviced by professionals who are certified in the United States by NFI (National Fireplace Institute®) or in Canada by WETT (Wood Energy Technical Training) or in Quebec by APC (Association des Professionnels du Chauffage).

2.0 General Information

2.1 FP7LM Antoinette Wood Fireplace Specifications

Fuel Type	Cordwood
Test Standards (safety)	ULC S610 and UL 127
Test Standards (emissions)	ASTM 2515 and ASTM 2558 U.S. EPA Low Mass Wood-burning Fireplace voluntary program phase 2 emission level qualified model
Shipping Weight	673 lb (305 kg)
Maximum Log Length recommended	18" east-west
Flue Outlet Diameter:	8" (203 mm) diameter (vertical)

2.2 *The Benefits of EPA Voluntary Emission Program «Low Mass» Phase II*

In the past, most conventional masonry and low-mass, factory-built fireplaces were not efficient at producing usable heat. Typically, over 90 percent of the heat generated by a fireplace was lost out the chimney. In addition, many of these fireplaces were sources of smoke, indoors and out.

In 2009, the US Environmental Protection Agency (EPA) initiated a voluntary program for manufacturers of decorative wood burning fireplaces to encourage manufacturers to produce clean wood-burning appliances that reduce air pollution. Under the U.S. EPA Low Mass Fireplace Voluntary Program, cleaner burning fireplaces are ones that qualify for the Phase I emission levels of 7.3 g/kg (approximately 57 percent cleaner than unqualified models) or the Phase II emission levels of 5.1 g/kg (approximately 70 percent cleaner than unqualified models). Participating manufacturers are expected to qualify under Phase 2 by 2013. The FP7LM Antoinette wood fireplace is a phase II emission level qualified model that brings you the benefits of lower emissions.

3.0 **Fireplace Installation**

ATTENTION: IN ORDER TO COMPLETE THE FIREPLACE INSTALLATION AND DEPENDING ON THE TYPE OF FINISHING MATERIAL USED, YOU MUST INSTALL ONE OF THE FOLLOWING TRIMS; A NARROW OVERLAP (A) OR A MASONRY TRIM (B) (SOLD SEPARATELY).

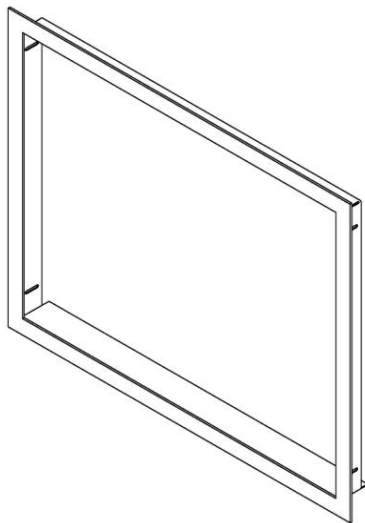

Figure 1 (A)
Narrow Overlap

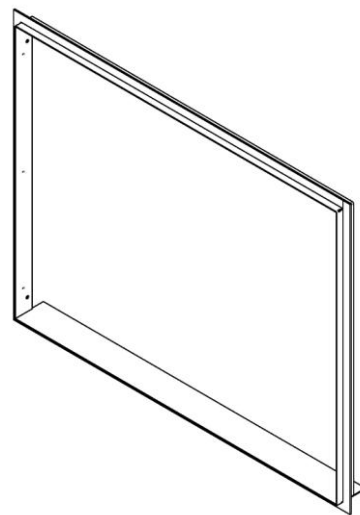

Figure 1 (B)
Masonry Trim

CAUTION: WHEN USING THE DECORATIVE APPLIANCE, THE FIREPLACE DAMPER MUST BE SET IN THE FULLY OPEN POSITION.

3.1 Installation of Spacers and Heat Shield

To complete the fireplace, spacers and heat shield must be secured to the top of the appliance. These parts are required to maintain proper clearances to combustible materials. You will find the spacers, heat shield and screws in the firebox (see Figure 2 and 3).

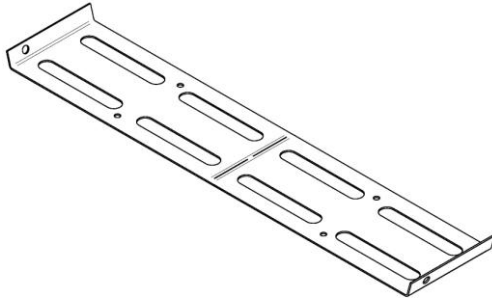

Figure 2
Spacers (2X)

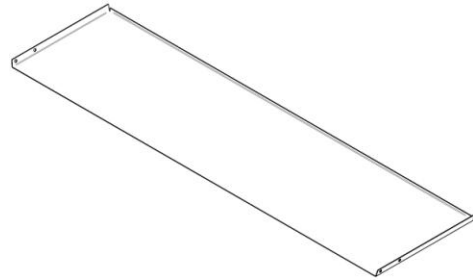

Figure 3
Heat shield (1X)

3.1.1 Spacers

1. Fold by hand the 2 spacers like illustrated in Figure 4.

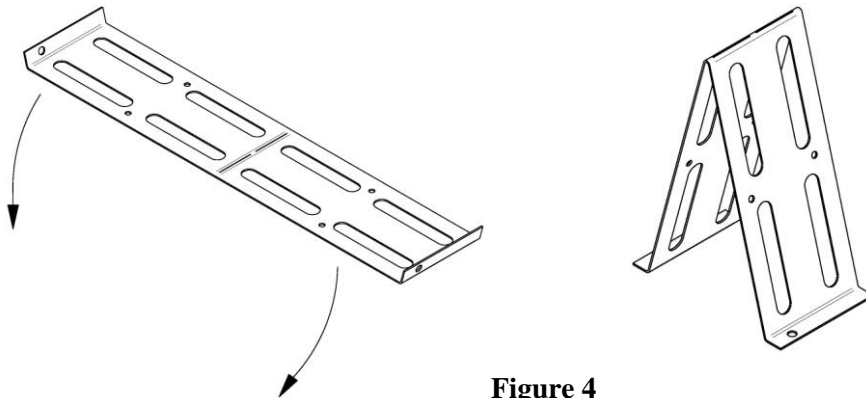

Figure 4

2. Align the holes of the spacers (A) with the pre-drilled holes on top of the fireplace and secure them with the 4 screws (B) as shown in Figure 5:

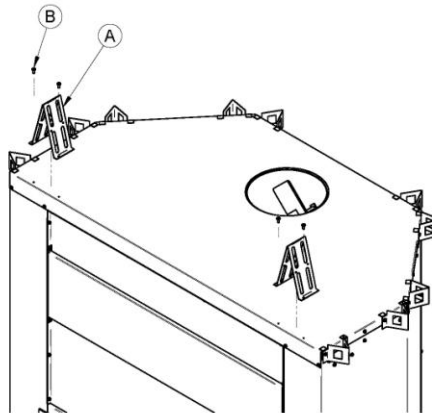

Figure 5

3. As illustrated in Figure 6 and 7, position the heat shield (C) between the spacers previously installed with the folds facing up. Align the holes of the shield with the ones of the left and right spacer and secure it with 4 screws (B).

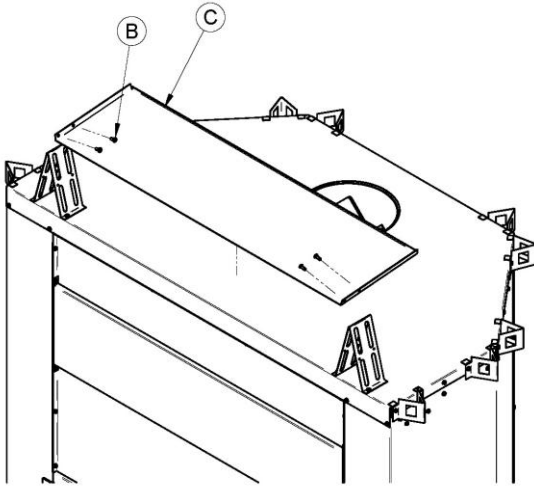

Figure 6

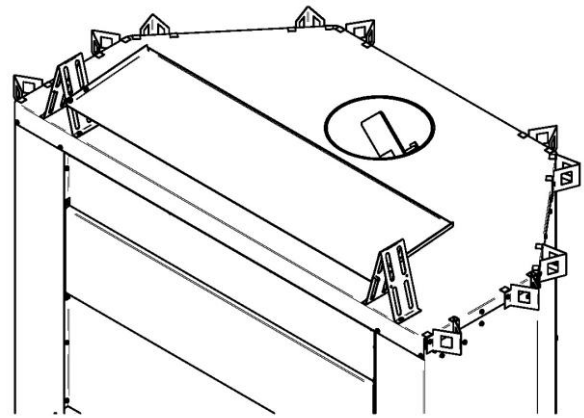

Figure 7

3.2 Fire Baffles Installation

Your fireplace FP7LM contains two fire baffles. In order to protect them during transportation, the small fire baffle (D) is located at the bottom of the combustion chamber, while the largest (E) is in the box in front of your fireplace door. Note that in order to install the small fire baffle (D) properly, it should lean against the back of the chimney throat, as shown in Figure 3.3 A. For the installation of the biggest fire baffle (B), it must be positioned as shown in Figure 3.3 B and lean against the front of the chimney throat.

Follow these steps to install the fire baffles:

1. To install the first fire baffle (D), hold it in your hands with the narrowest part towards the back of the unit (Figure 3.3 A).
2. Move the piece up to the top bracket at the back of the fireplace throat, taking care to avoid the bracket of the front fire baffle (Figure 3.3 C).
3. Place the baffle on its brackets and make sure it is leaning against the back of the chimney throat (Figure 3.3 D)
4. To install the front fire baffle (E), hold it in your hands with the narrow end toward the back of the fireplace (Figure 3.3 B).
5. Move the piece up, making sure to keep it close to the front wall of the chimney throat for easy maneuverability (Figure 3.3 E).
6. Once one side has exceeded its bracket, lean it against the side and front wall of the chimney throat for easy maneuverability. Then rotate the piece so that the other side is also above its support (Figure 3.3 F).
7. Place the baffle on its bracket and slide it horizontally to center it (Figure 3.3 G). Make sure the fire baffle is leaning against the front of the chimney throat.

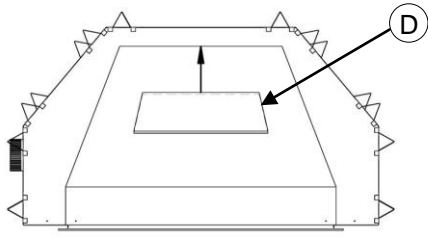

Figure 3.3 A

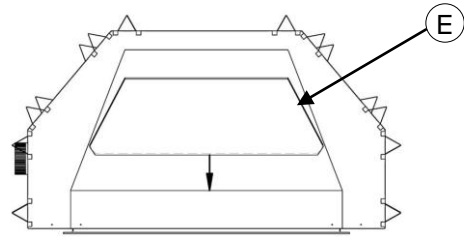

Figure 3.3 B

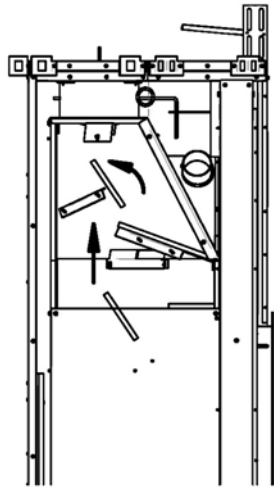

Figure 3.3 C

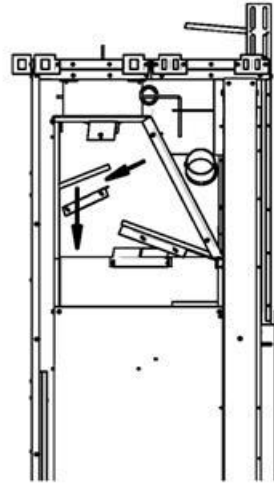

Figure 3.3 D

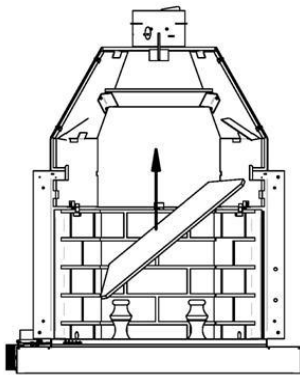

Figure 3.3 E

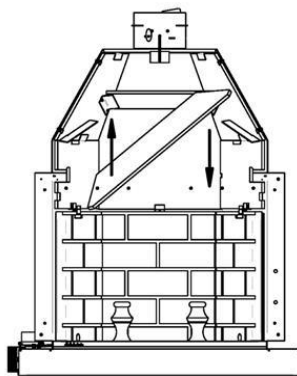

Figure 3.3 F

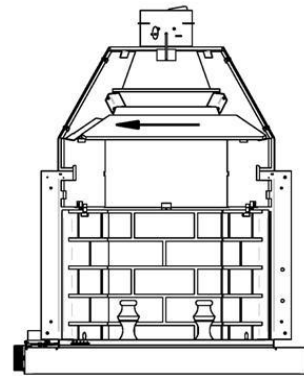

Figure 3.3 G

3.3 Locating the FP7LM Antoinette Wood Fireplace

- A. The best location to install your fireplace is determined by considering the location of windows, doors, and the traffic flow in the room where the fireplace is located, allowing space in front of the unit for the hearth extension and the mantel, and taking into consideration the location of the outside air kit and chimney. If possible, you should choose a location where the chimney will pass through the house without cutting floor or roof rafters.
- B. Usually, no additional floor support is needed for the fireplace. The adequacy of the floor can be checked by first estimating the weight of the fireplace system. Weights are given in the appendix. Next, measure the area occupied by the fireplace which is normally 49" x 27 1/8" (125 cm x 69 cm). Note the floor construction and consult your local building code to determine if additional support is needed.

CAUTION: BEFORE BEGINNING THE FIREPLACE INSTALLATION, CONSULT THE LOCAL AUTHORITIES TO OBTAIN YOUR BUILDING PERMIT AND CHECK YOUR LOCAL BUILDING CODES. INSTALL THE FIREPLACE ONLY AS DESCRIBED IN THESE INSTRUCTIONS AND USE ONLY THE MANUFACTURER'S COMPONENTS LISTED IN TABLE 1.

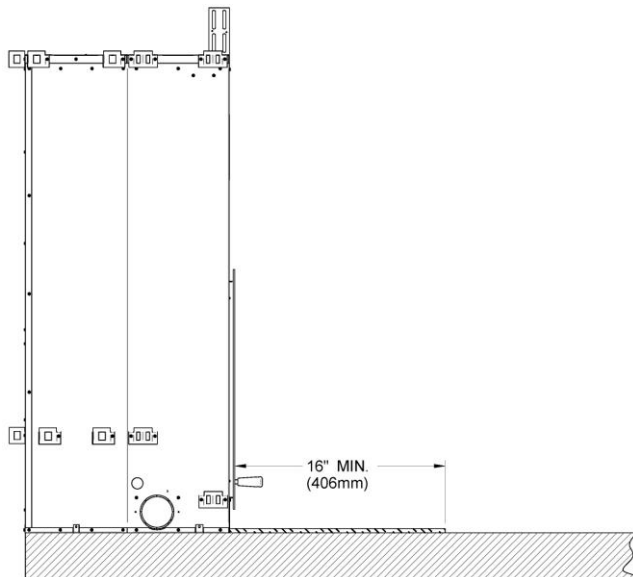

Figure 8 Installation on raised base

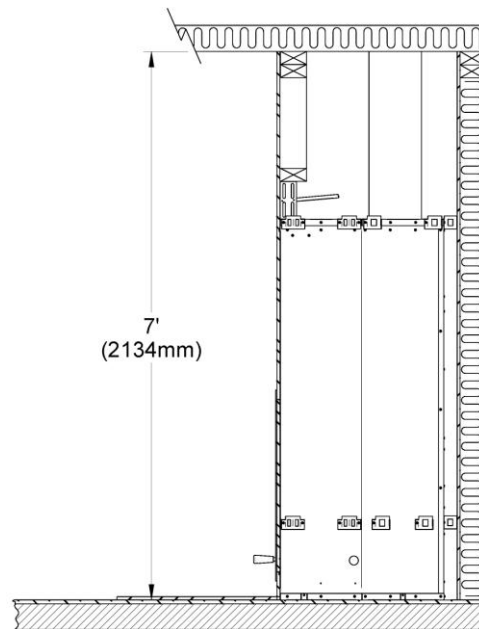

Figure 9 Ceiling clearance requirements

3.4 *Hearth Extension Requirements*

The hearth extension floor area (see (A) on Figure 10) must extend at least 16" (40 cm) in front and at least 8" (20 cm) on each side of the door opening (see Figures 8 and 10). The joint between the hearth extension and the fireplace hearth needs to be made of non-combustible material such as sheet metal or sand-cement grout (not included) as shown on Figure 11.

WARNING: THE HEARTH EXTENSION IS TO BE INSTALLED ONLY AS ILLUSTRATED. (See Figure 11)

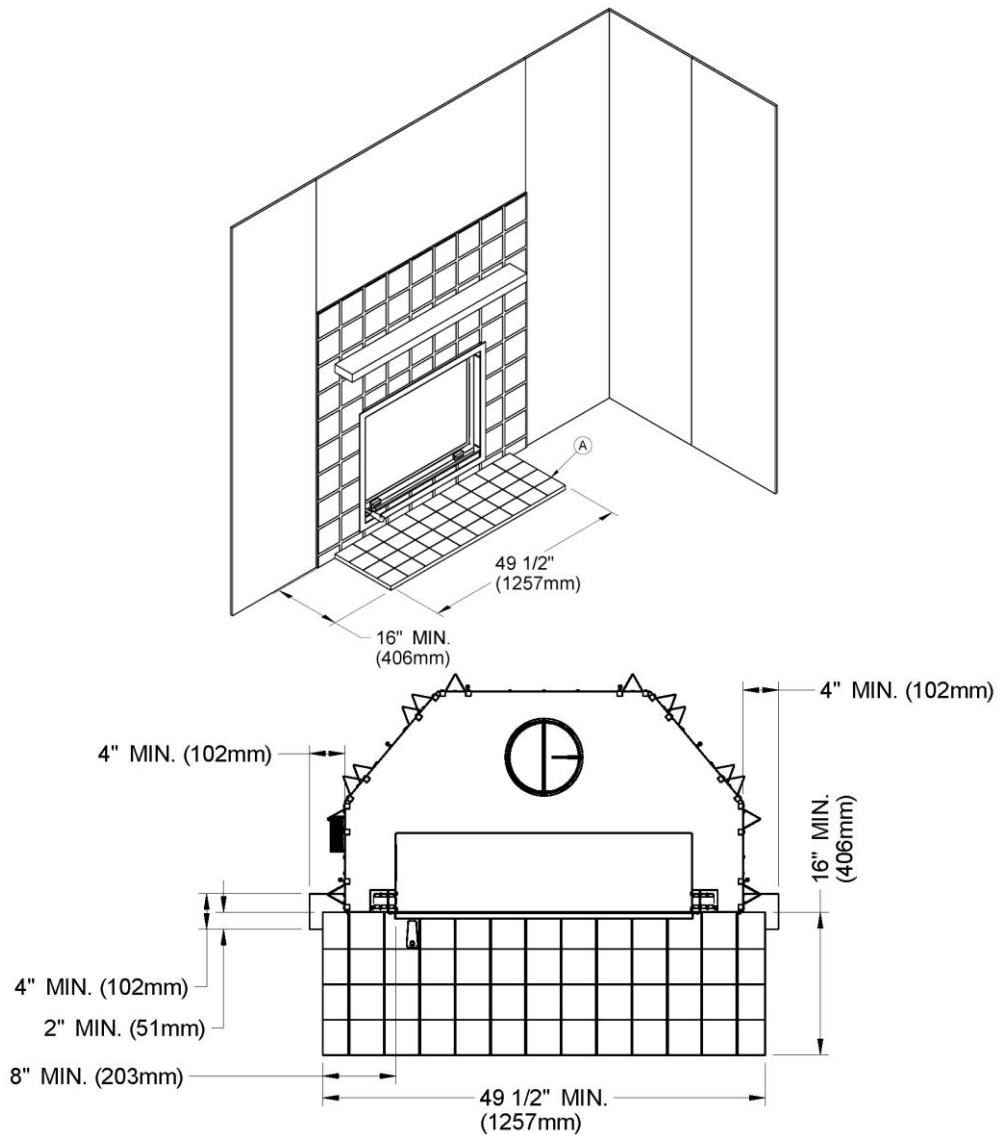

Figure 10

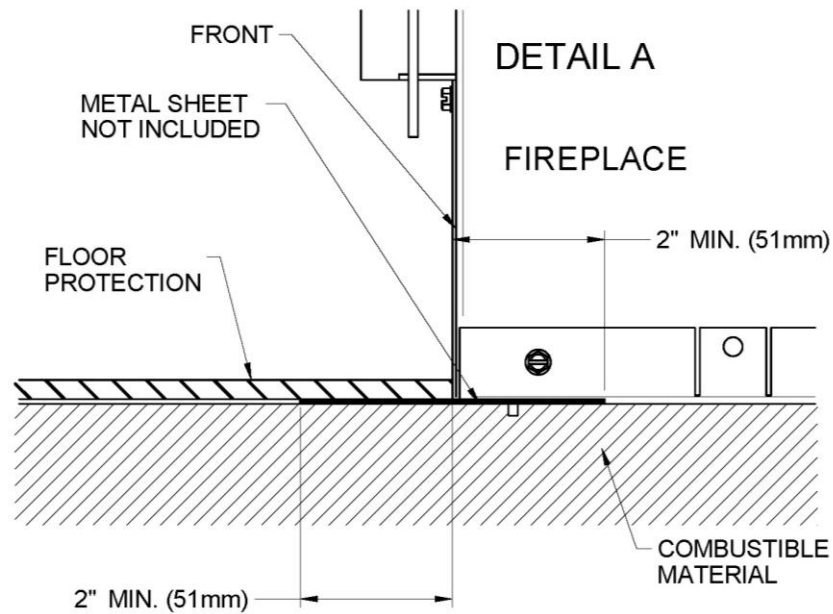
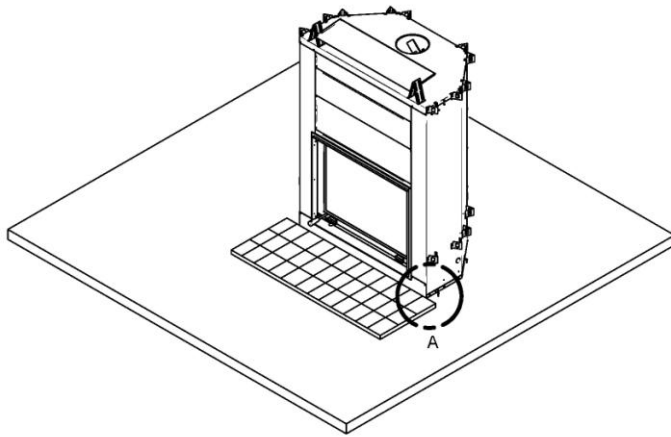

Figure 11

3.5 Framing, Facing, Mantel, and Combustible Shelf

3.5.1 Framing

The construction of the framing, facing, and mantel must be in accordance with the standards and the following illustrations (Figures 12 to 18):

- A. Frame the fireplace using 2" x 3" (5 cm x 8 cm) or heavier lumber.

WARNING: COMBUSTIBLE FRAMING MATERIAL CANNOT BE USED IN THE SPACE DIRECTLY ABOVE THE FIREPLACE, EXCEPT FOR THE STUDS ABOVE THE FACING THAT SUPPORT THE FACING MATERIAL AND MANTEL. THIS AREA MUST REMAIN EMPTY FOR A HEIGHT OF 7' (2,15 M) MEASURED FROM THE BASE OF THE APPLIANCE.

B. Frame the fireplace with vertical studs on each side of the fireplace running from floor to ceiling (see Figure 15). Position the studs back from the front edge of the fireplace, leaving a space the thickness of the facing material so that the facing can be installed flush with the fireplace facing (within limitations of Figure 15). Frame headers between the vertical studs only as follows:

- Place 2 x 3 or 2 x 4 headers, only along the upper part of the front, side and back faces. Do not put wood or any combustible material within the area above the fireplace except on the front facing.
- Place headers only as required to support the facing and mantel.

WARNING: DO NOT PACK REQUIRED AIR SPACES WITH INSULATION OR OTHER MATERIAL.

WARNING: THE FIREPLACE MUST NOT BE IN CONTACT WITH ANY INSULATION OR LOOSE FILLING MATERIAL. COVER THE INSULATION WITH DRYWALL PANELS AROUND THE FIREPLACE.

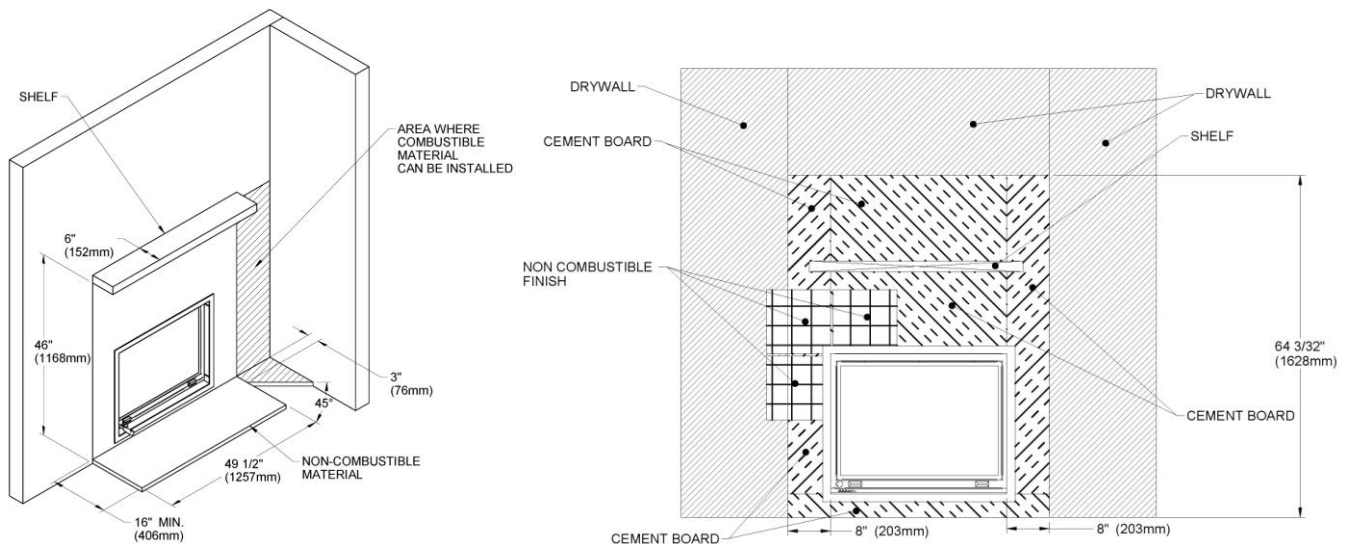

Figure 12 (a)

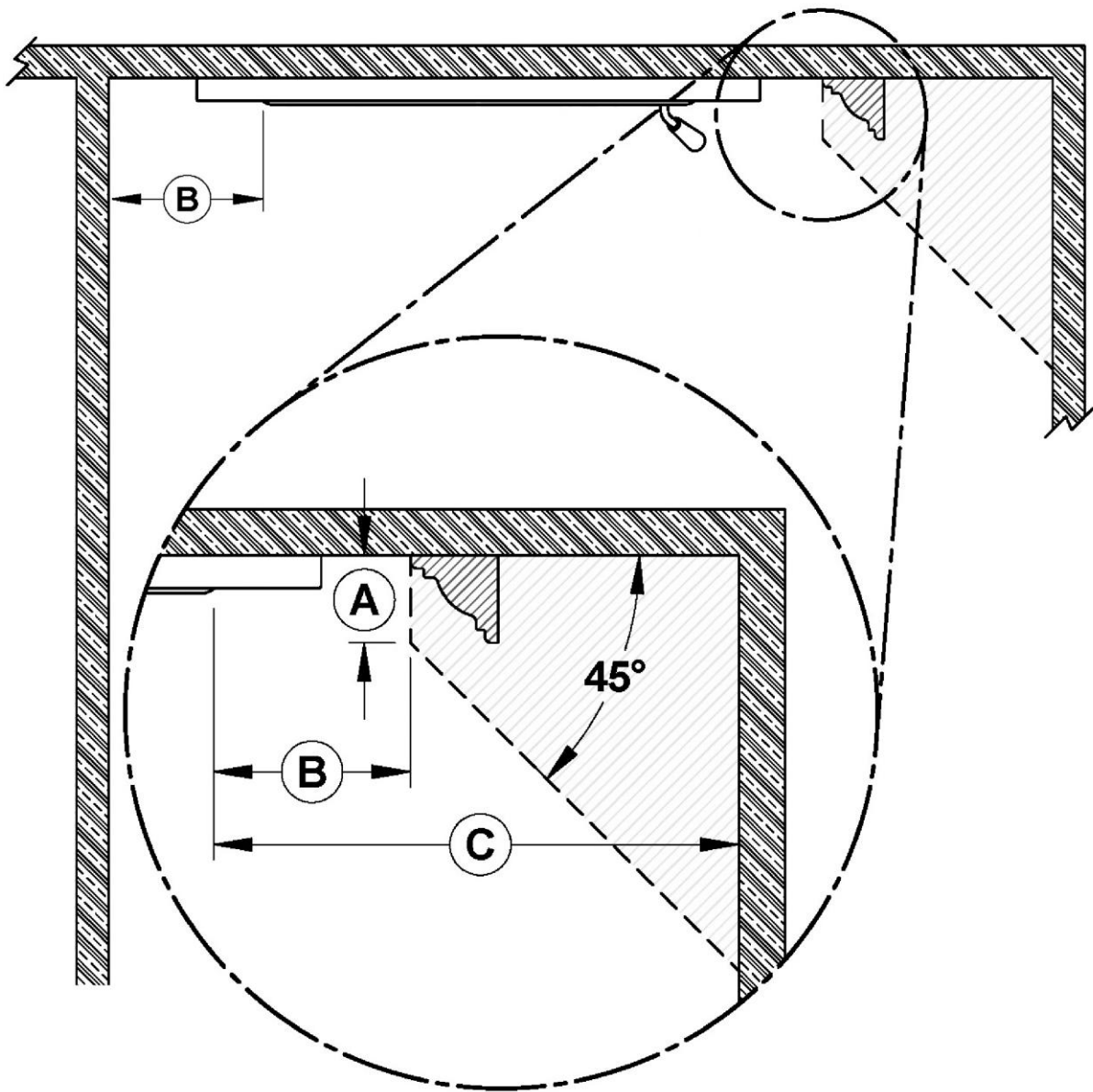

Figure 12 (b)

	CLEARANCES*
A	3" (76 mm) maximum
B	8" (203 mm) minimum
C	20" (508 mm) minimum

*The fireplace can be installed against one of the walls in the room, respecting minimum value (B) from door opening. If the fireplace has a wall built against one side of the fireplace, the other sidewall must respect minimum value (C) from door opening. The fireplace may also have a combustible side mantle respecting values (A) and (B).

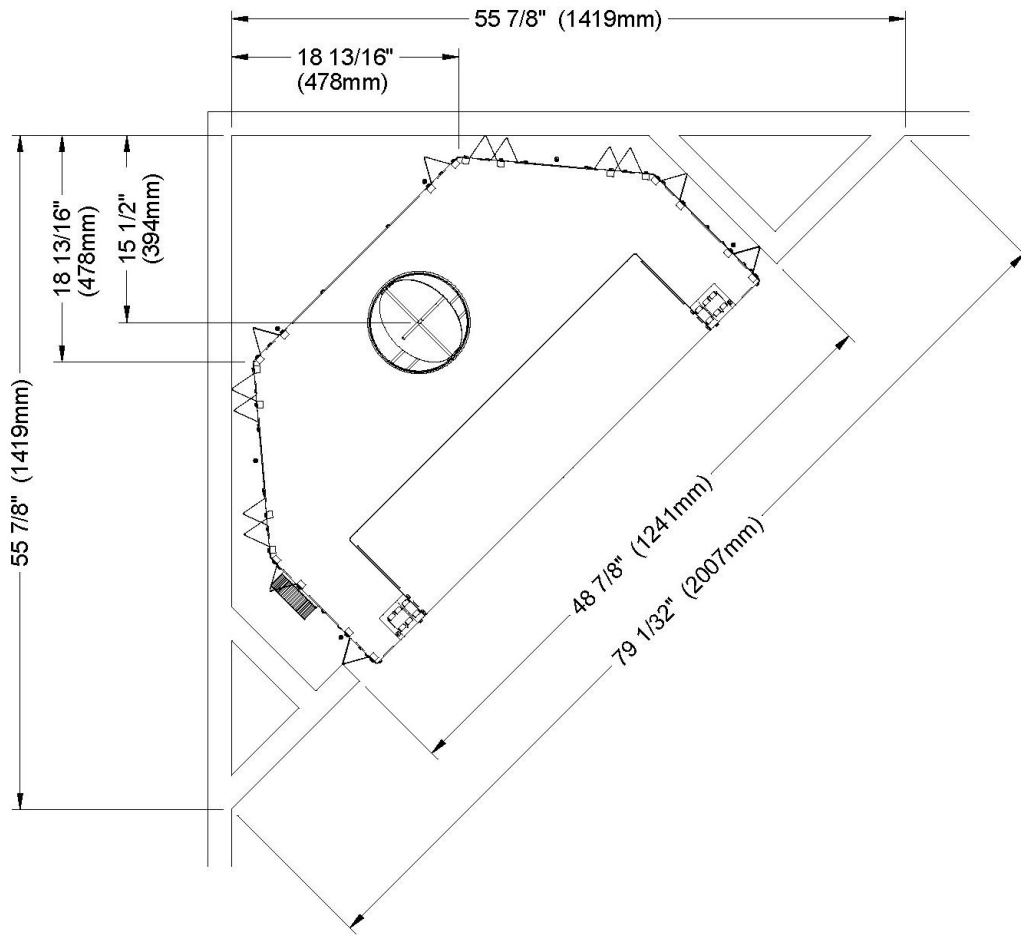

Figure 13

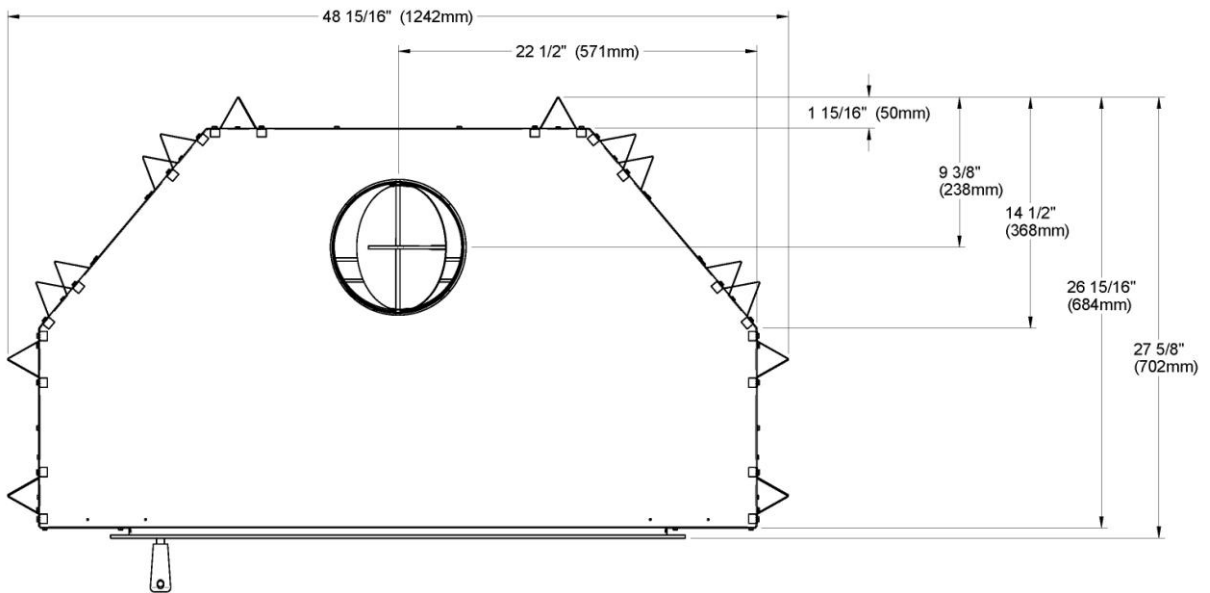

Figure 14

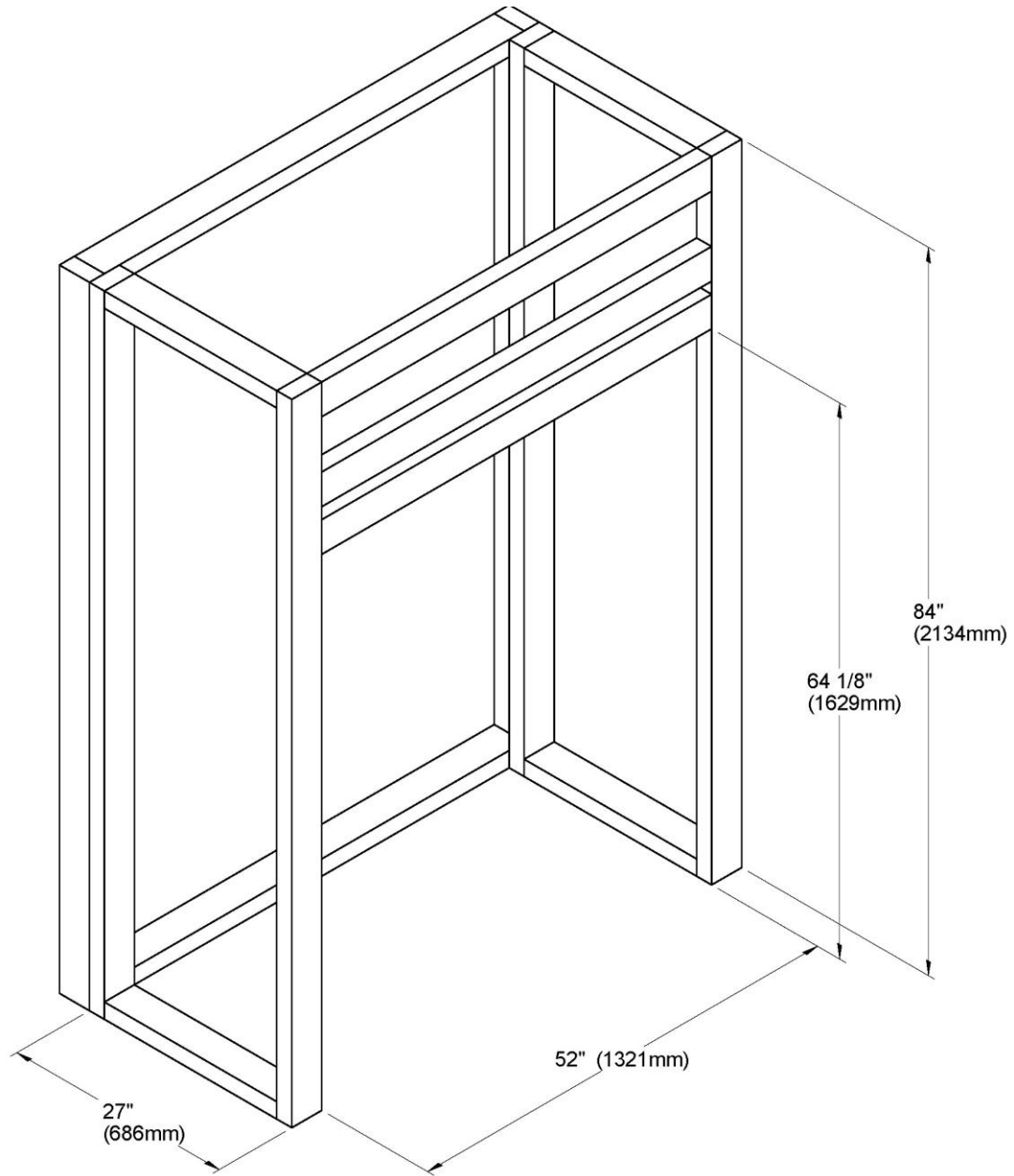

Figure 15

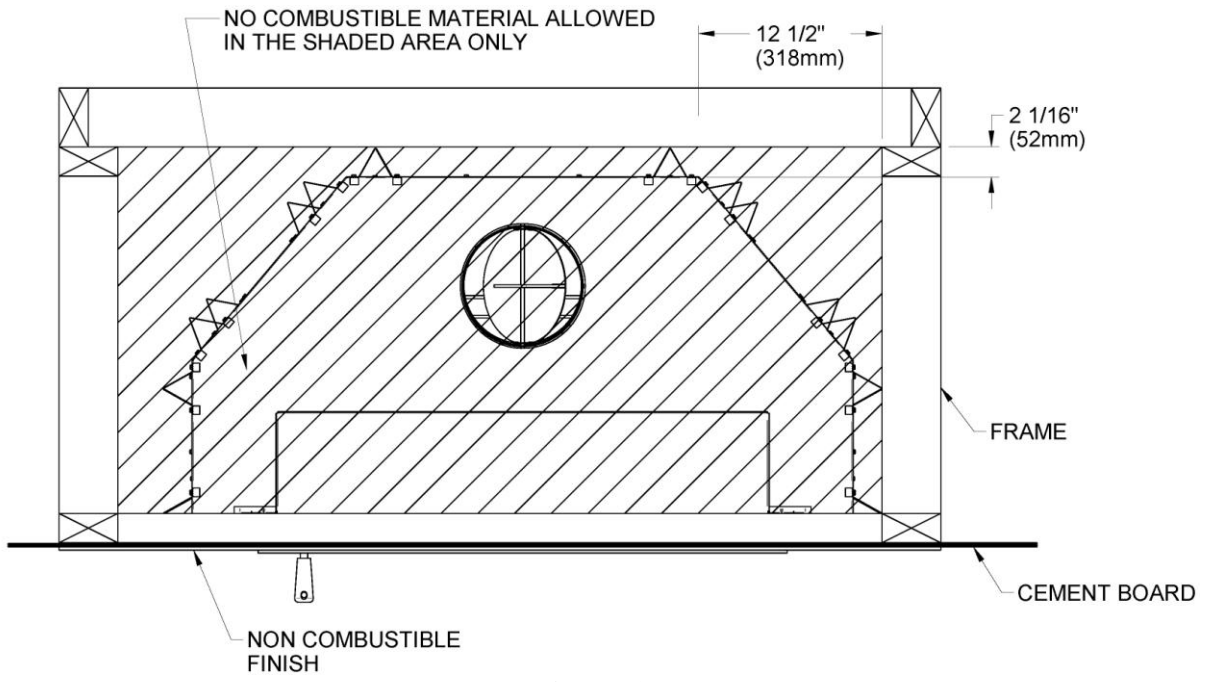

Figure 16

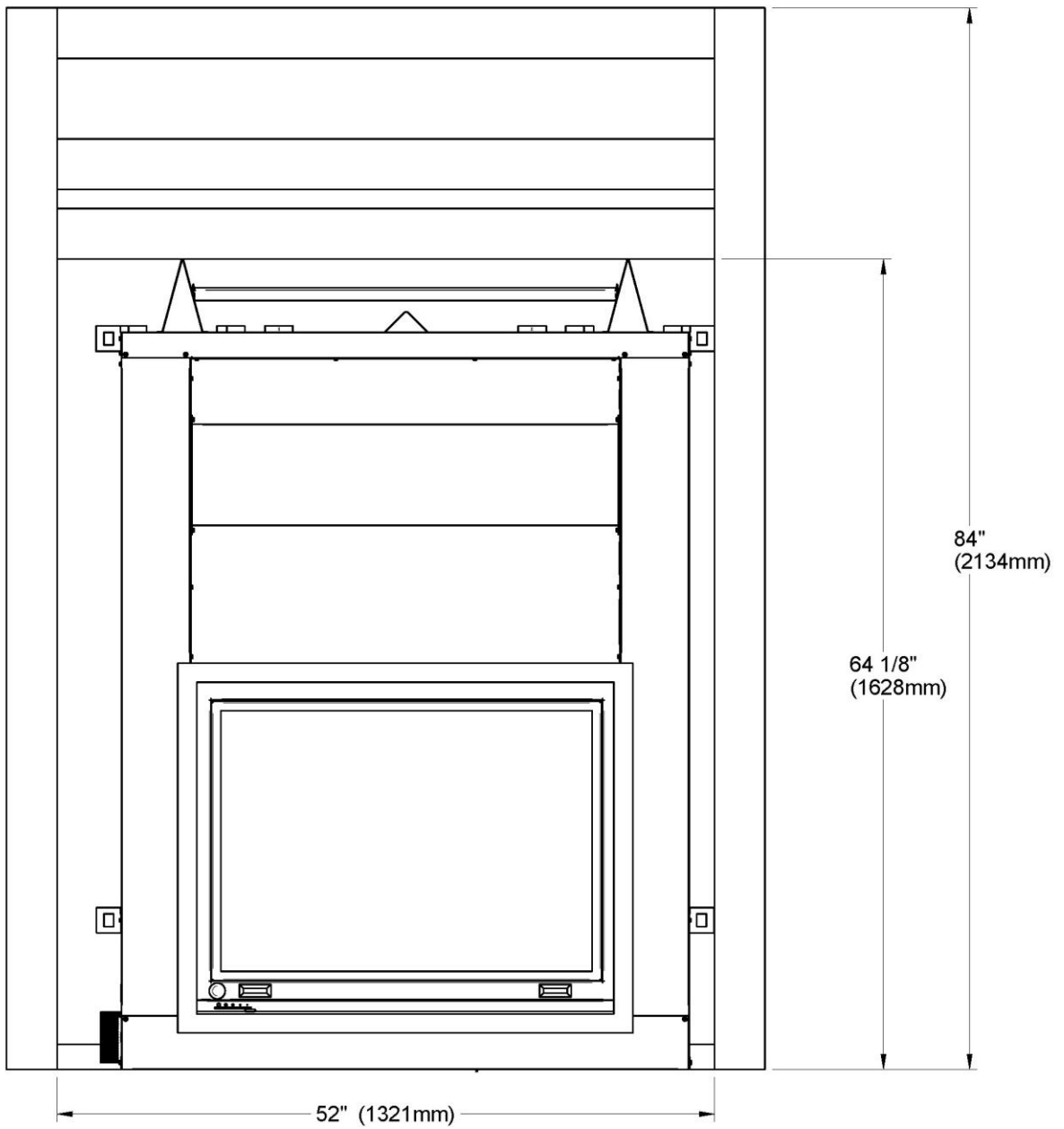

Figure 17
Insulated chase construction

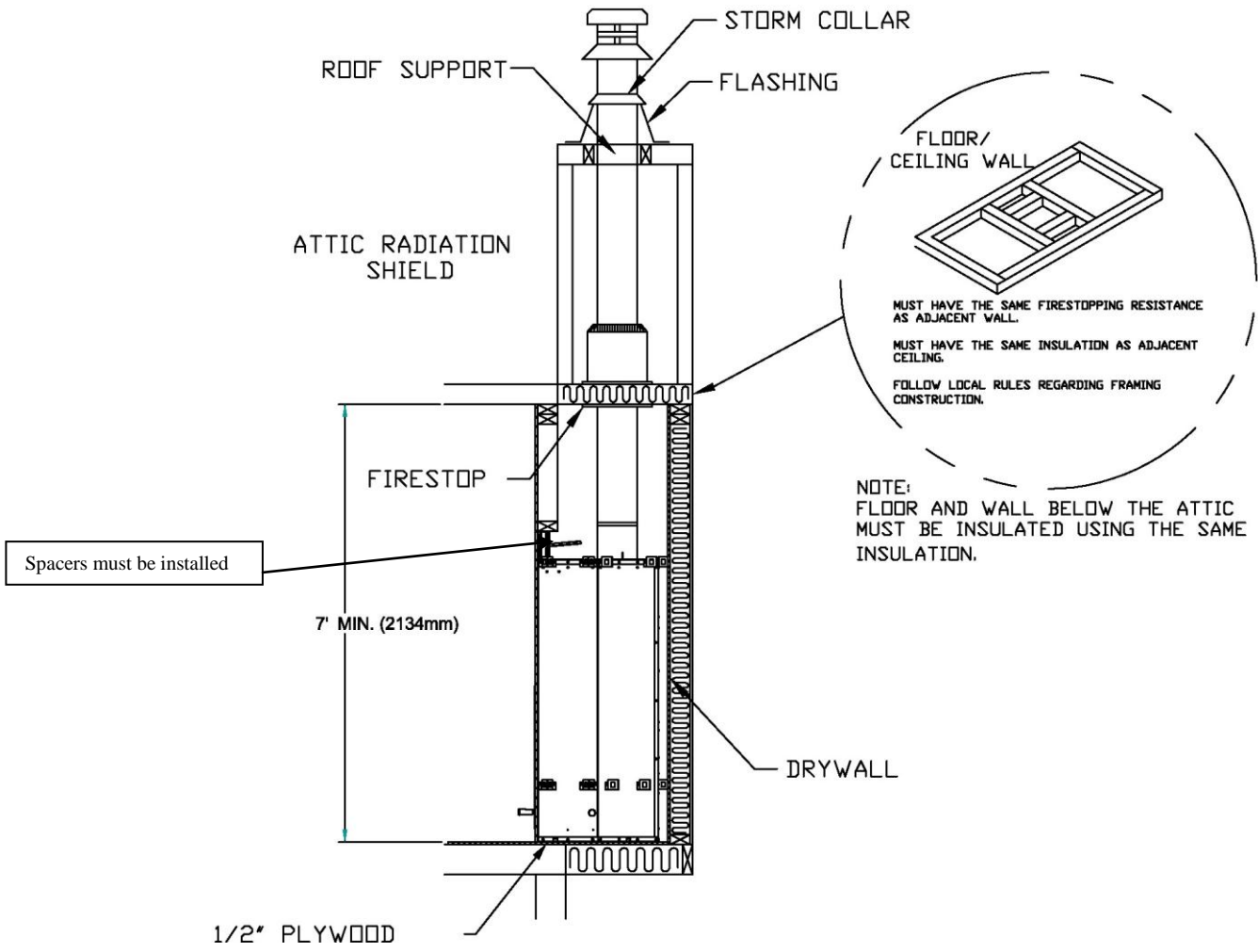

Figure 18

3.5.2 Facing

CAUTION: BEFORE CLOSING THE WALLS, MAKE SURE THAT THE AIR CONTROL MECHANISM, THE FLUE DAMPER AND DOORS MECHANISM WORK PROPERLY.

ATTENTION: IF YOU ARE TO INSTALL A MASONRY TRIM, IT MUST BE SECURED TO THE FIREPLACE BEFORE APPLYING THE FINISHING MATERIAL. (See Section 3.6.1)

1. Materials directly in contact with the faceplate of the fireplace, especially the vertical and horizontal surround, must be non-combustible and have the minimal dimensions as shown on Figure 12.
2. Non-combustible materials such as brick, stone or ceramic tile may project in front of and onto the fireplace decorative frame.

CAUTION: MATERIALS MUST BE INSTALLED SO THAT THE FACEPLATE MAY BE REMOVED AFTER THE INSTALLATION. THE FACEPLATE IS DESIGNED TO OVERLAP THE MATERIAL SURROUNDING THE FIREPLACE. IF THE MATERIAL IS THICKER, USE A FACEPLATE GAUGE FOR POSITIONING AND MAKE SURE THAT THE FACEPLATE CAN BE REMOVED AFTER IT HAS BEEN INSTALLED (PLEASE DISMISS IF YOU INSTALL THE MASONRY FACEPLATE OPTION).

Facing With the Narrow Overlap

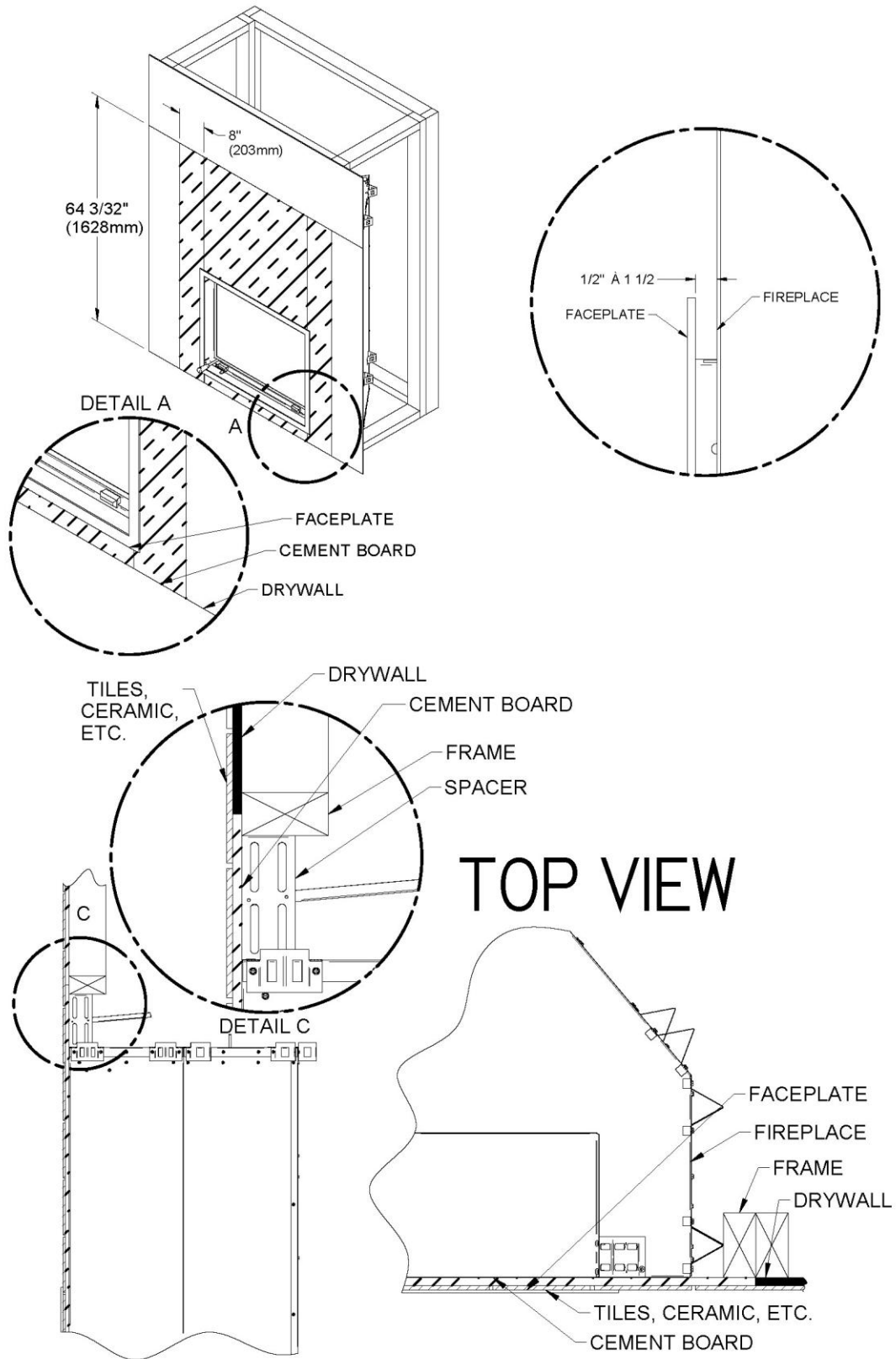

Figure 19

Facing With the Masonry Trim

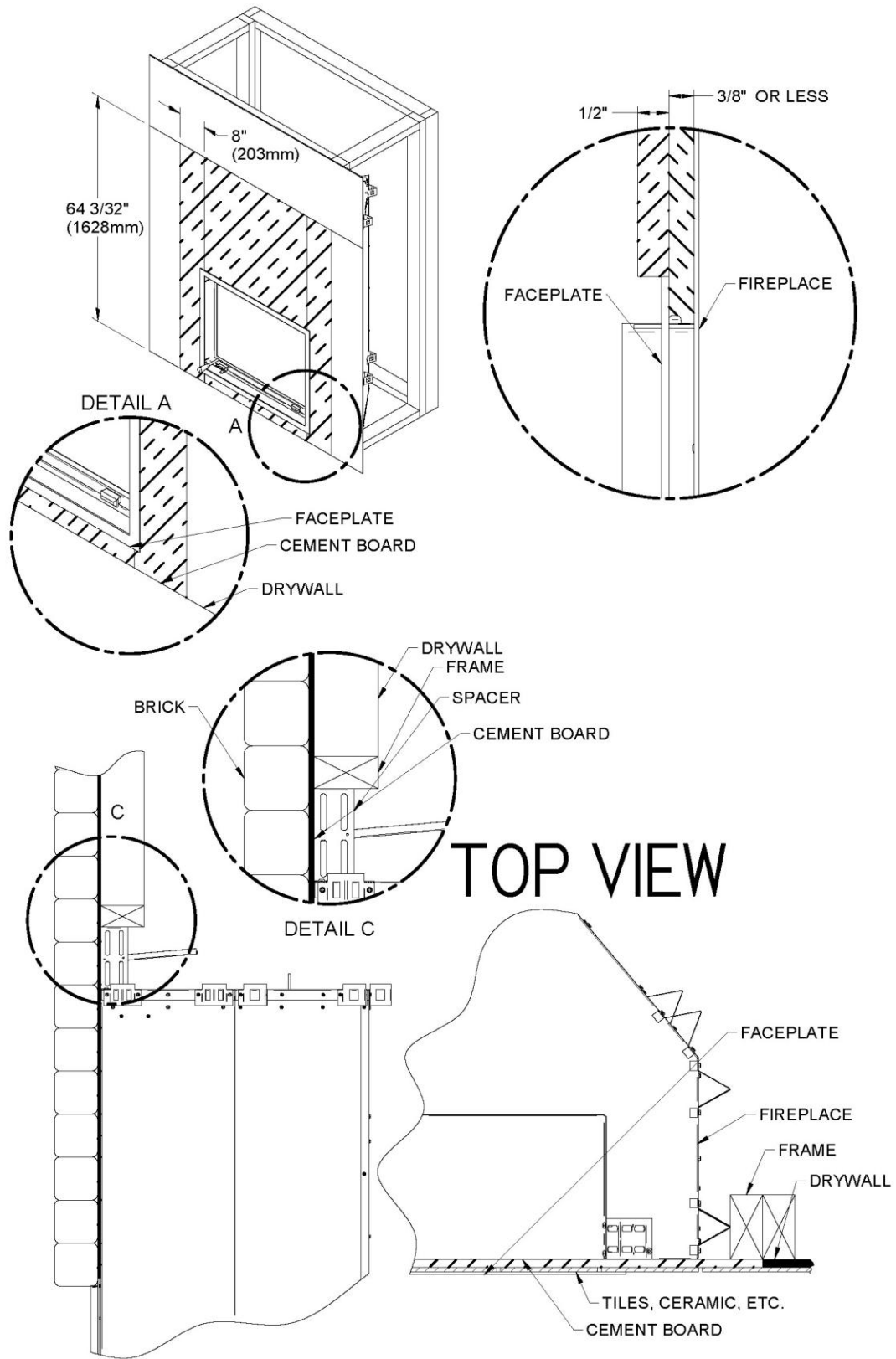

Figure 20

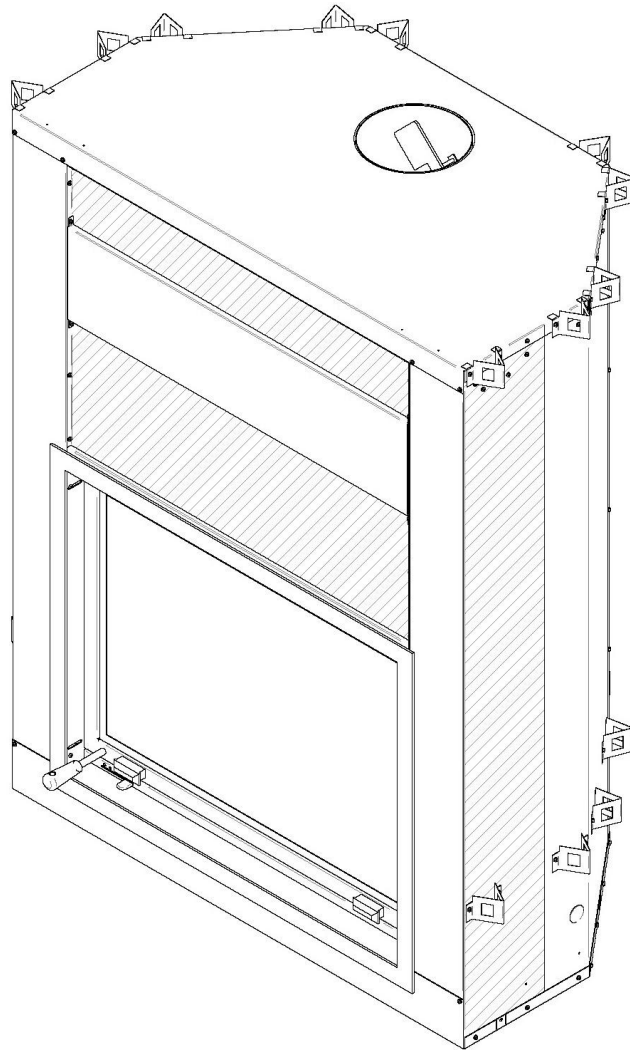

Figure 21

CAUTION: DO NOT SCREW IN THE HATCHURED ZONE (See Figure 21)

3.6.3 Combustible Shelf

To install any combustible shelf, refer to Figure 22 for a safe installation. For example, a shelf with a 6" depth (152 mm) must be installed at least 46" (127 cm) from the base of the fireplace. Different shelf dimensions are listed in the table below and in Figure 22 in order to facilitate installation. The depth of the shelf can be 6" or less but can't be installed at less than 46" (127 cm) from the base of the fireplace. If the depth of the shelf is not listed in the table, add 40" (102 cm) to the depth of your shelf to obtain the safe positioning of your shelf. For example, for a 9" shelf, the safe positioning would be 49" (40 inches + 9 inches) the base of the fireplace.

SHELF POSITIONING	
SHELF DIMENSION	SHELF POSITION
<i>6" / 152 mm</i>	<i>46" / 1168 mm</i>
<i>8" / 203 mm</i>	<i>48" / 1219 mm</i>
<i>10" / 254 mm</i>	<i>50" / 1270 mm</i>
<i>12" / 305 mm</i>	<i>52" / 1321 mm</i>

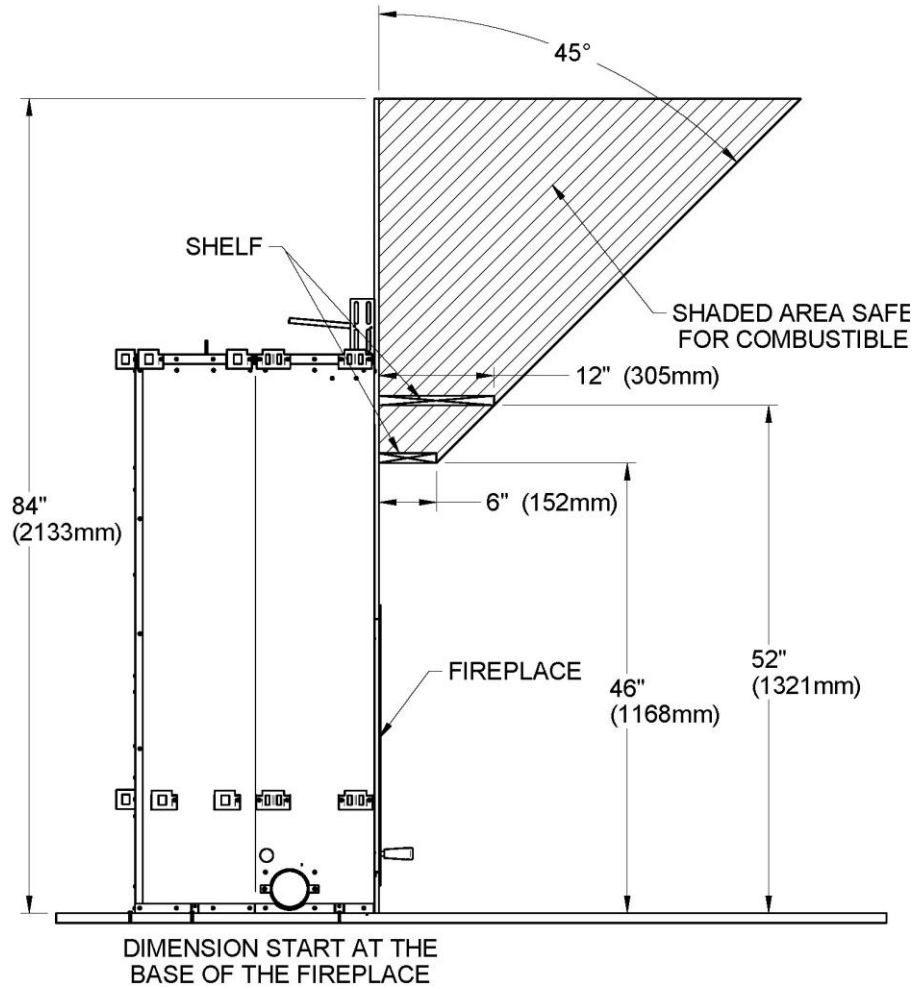

Figure 22

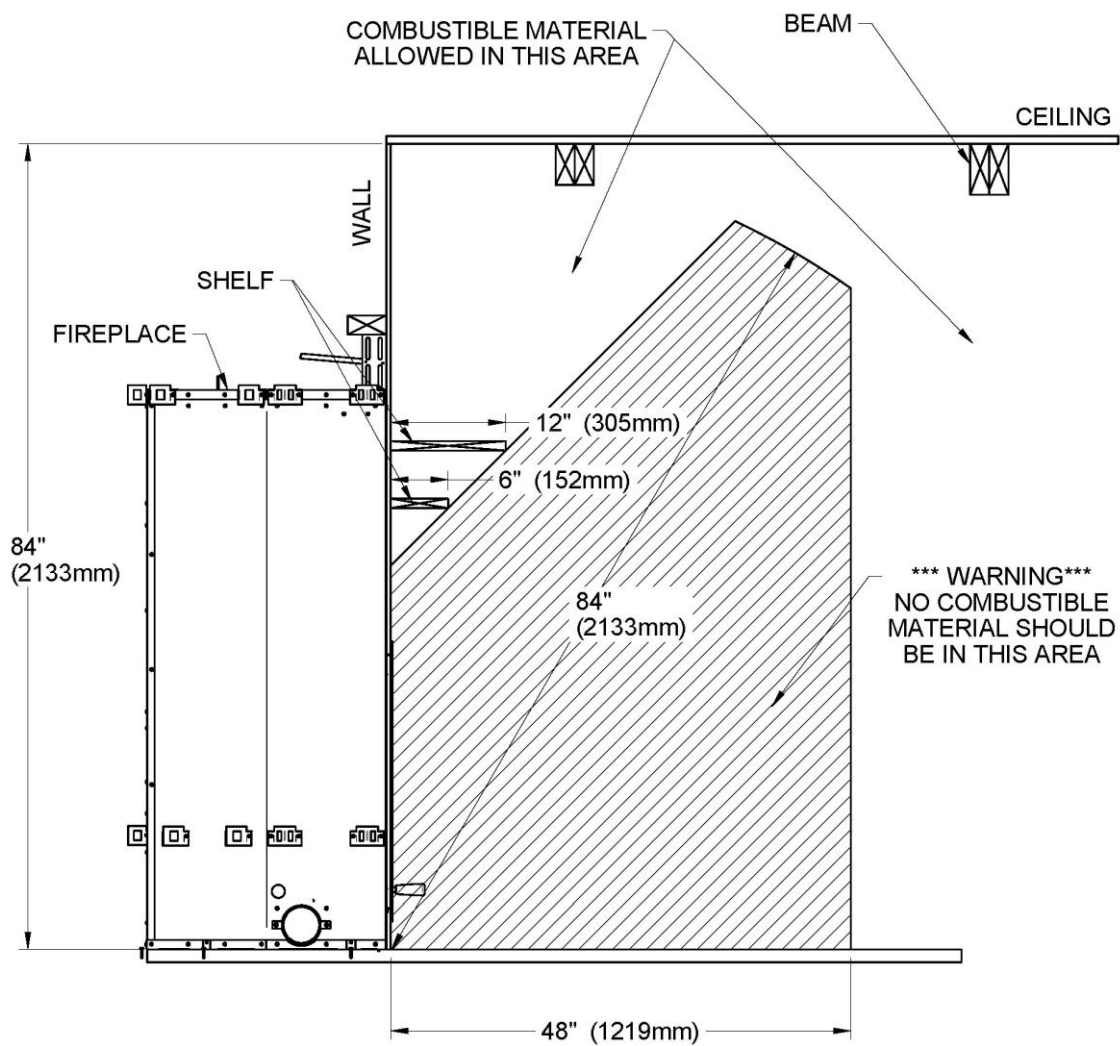

Figure 23

3.6 *Fresh Air Kit*

During operation, the fireplace requires fresh air for combustion and draws air out of the house. It may starve other fuel burning appliances such as gas or oil furnaces. As well, exhaust fans may compete for air, causing negative pressure in the house, resulting in smoke entering the house from the fireplace. This situation is aggravated in modern airtight houses. To overcome this problem, we strongly recommend that you **bring fresh air to the fireplace. Check with local authorities having jurisdiction in your area, it may be mandatory.**

3.6.1 Fresh Air kit Installation

Refer to the following requirements to install a fresh air kit to the fireplace:

- A) Insulated duct length should be sufficient to avoid condensation.
- B) The outside wall termination must not be installed more than 10 ft. (3 m) above the base of the fireplace.
- C) The fresh air must come from outside the house. The air intake must not draw air from the attic, from the basement, or from a garage.
- D) The outside wall termination should be installed where it is not likely to be blocked by snow or exposed to extreme wind and away from automobile exhaust fumes, gas meter and other vents.
- E) The outside termination may be installed above or below floor level.

Your fireplace contains the following components:

- One (1) 4" adapter (B);
- Six (6) screws (C);

The following components are not included:

- A 4" insulated flexible pipe
- The outside air inlet cap
- The 2 adjustable clamping ring

To complete the fresh air installation, you will need a 4" insulated flexible pipe. Use the length required for your installation while respecting the maximum length of 10 ft (3 m).

Remove the knock (A) out located on the left-hand side of your fireplace. Install 4" adapter (B) included in your fireplace with the 2 screws (C).

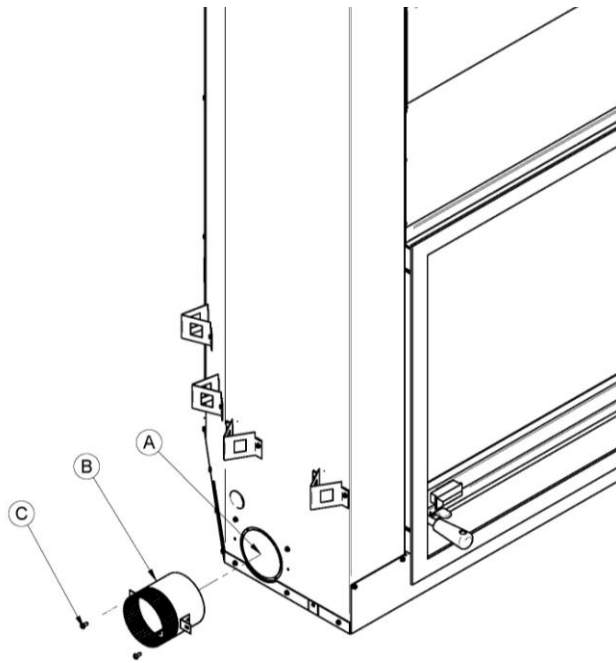

Figure 24

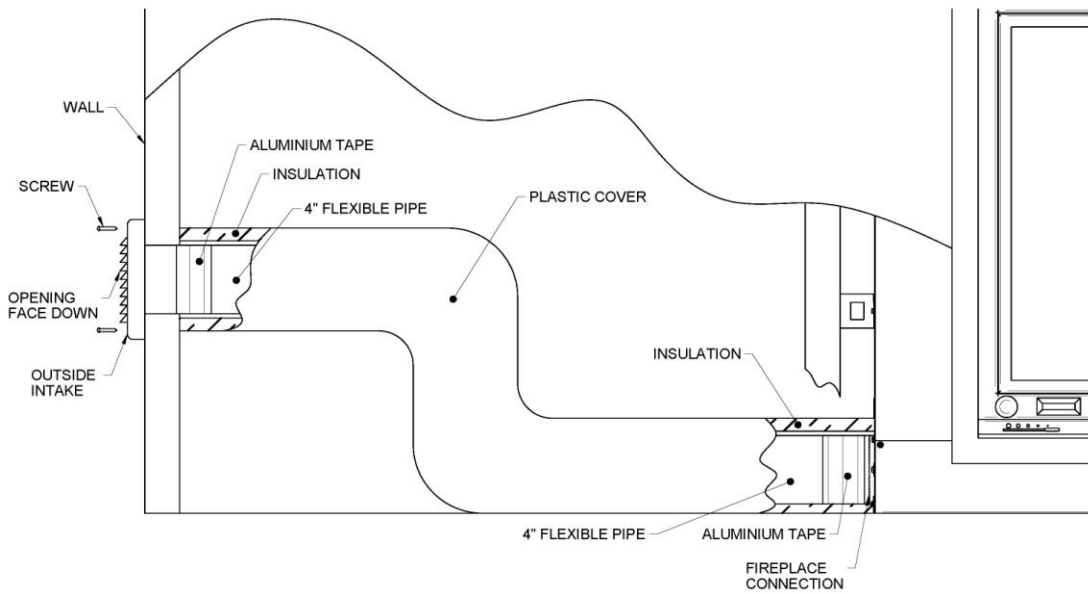

Figure 25

Perform an opening in the exterior wall according to the size of the wall termination. From outside, place the outside air inlet cap in the hole (open side down) and fasten the register to the wall, with screws as shown. Place the insulated pipe over the register tube and over the fireplace outside air connector (see Figure 25). At each end, carefully pull back the insulation and plastic cover, exposing the flexible pipe. Attach the flexible pipe using clamping rings. For a better seal, you may also use aluminum tape. Wrap the tape around the joint between the flexible pipe and the air inlets. Carefully push the insulation and plastic cover back over the pipe. Secure the plastic in place using aluminum tape.

3.7 *Faceplate Installation (Sold Separately)*

3.7.1 Narrow Overlap

WARNING: THE FACING SHOULD NEVER COME IN CONTACT WITH MASONRY PRODUCTS SUCH AS MORTAR, ACID OR ANY OTHER PRODUCTS CONTAINING ABRASIVES. DAMAGES AND DISCOLOURATION CAUSED BY THESE PRODUCTS WILL VOID THE WARRANTY.

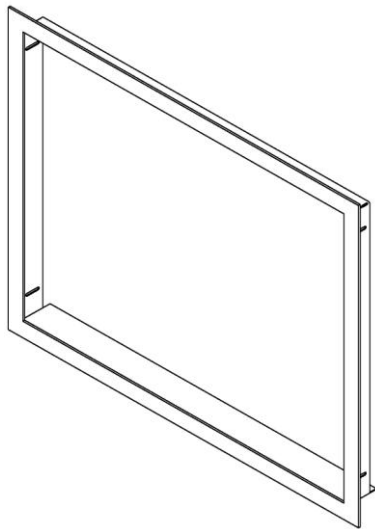

Figure 26
Narrow Overlap

1. Once the fireplace is fully installed, push the faceplate (C) against the non combustible material, which must be installed on the front of the fireplace.
2. Secure the faceplate (C) to the fireplace with 4 screws (B) supplied with the fireplace. Always make sure the faceplate is squared to the fireplace.
3. Make sure that the doors still slide perfectly.

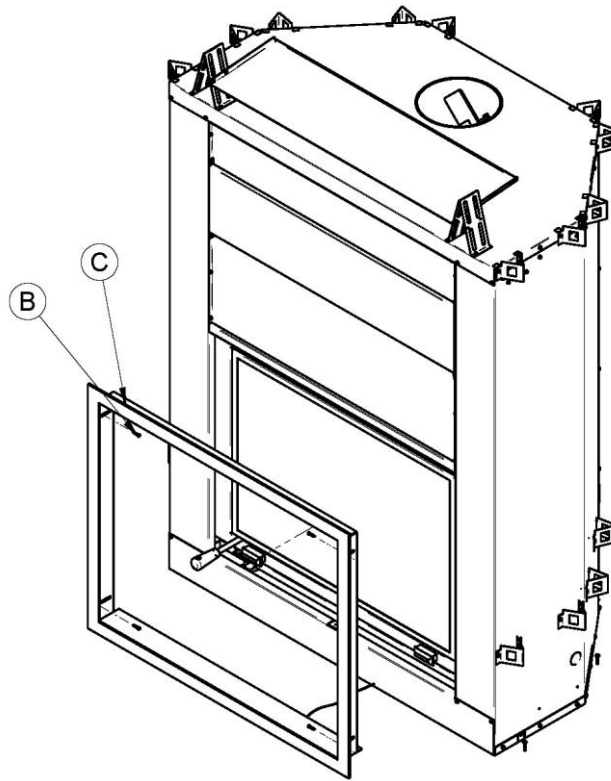

Figure 27
Narrow Overlap

3.7.2 Masonry Trim

WARNING: THE PLATING OF THE MASONRY TRIM SHOULD NEVER COME IN CONTACT WITH MASONRY PRODUCT SUCH AS MORTAR, ACID OR ANY OTHER PRODUCTS CONTAINING ABRASIVES. DAMAGES AND DISCOLOURATION CAUSED BY THESE PRODUCTS WILL VOID THE WARRANTY.

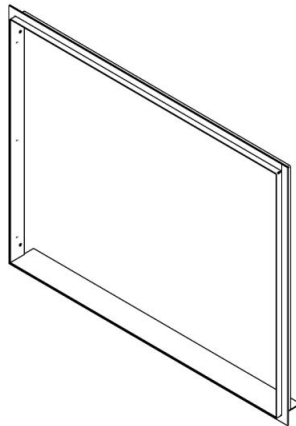

Figure 28.1
Masonry Trim

1. Once the fireplace is fully installed, press the masonry trim (A) against the fireplace (the longest side towards the bottom going inside the fireplace).
2. Secure the masonry trim (A) to the fireplace with 4 screws (B) supplied with the fireplace. Always make sure the masonry trim is squared to the fireplace.
3. Make sure that the doors still slide perfectly.
4. Once the trim is installed, you may proceed with the installation of the non combustable wall (all types of cement board). See section 3.6.2.
5. Install the non combustable material on top of the cement board and against the exceeding side of the masonry trim (A).

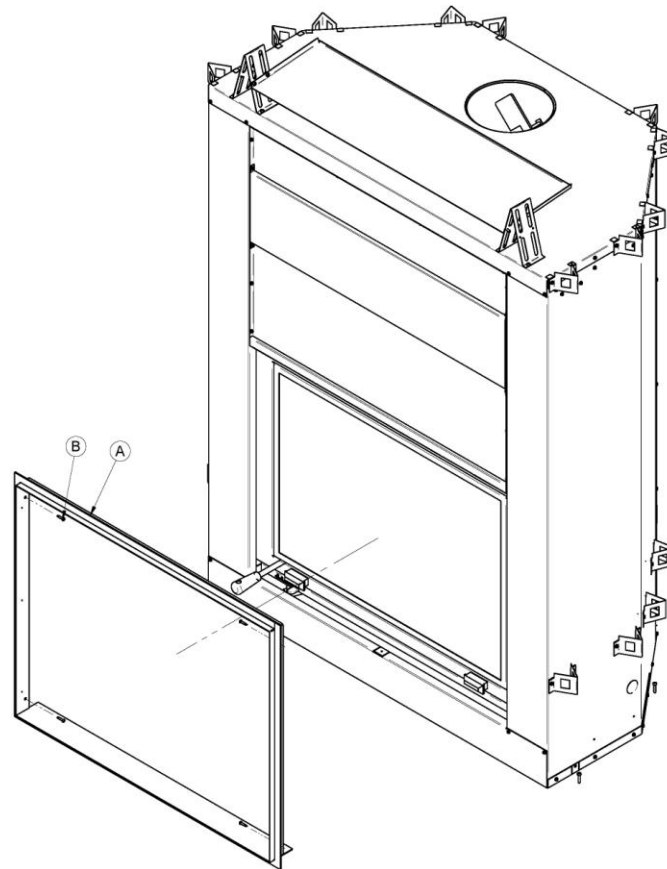

Figure 28.2
Masonry Trim

3.8 *Door Alignment*

To adjust glass door

1. Move the screen door completely to the top.
2. Move down the glass door to the bottom.
3. Unscrew the two bolts (A) which are located on the lower left of the door (See Figure 29).
4. To adjust, move the door to the left or right as needed.
5. Tighten the 2 bolts.

To adjust screen door

1. Lift the screen and the glass door completely to the top.
2. Unscrew one of the two bolts (A) which are located on the lower right of the screen door (See Figure 29).
3. Slightly unscrew the other bolt to allow the door adjustment.
4. Move down the screen door to the bottom.
5. To adjust, move the door to the left or right as needed.
6. Without changing the performed adjustment, move up about 6" the screen door.
7. Tighten the 2 bolts.

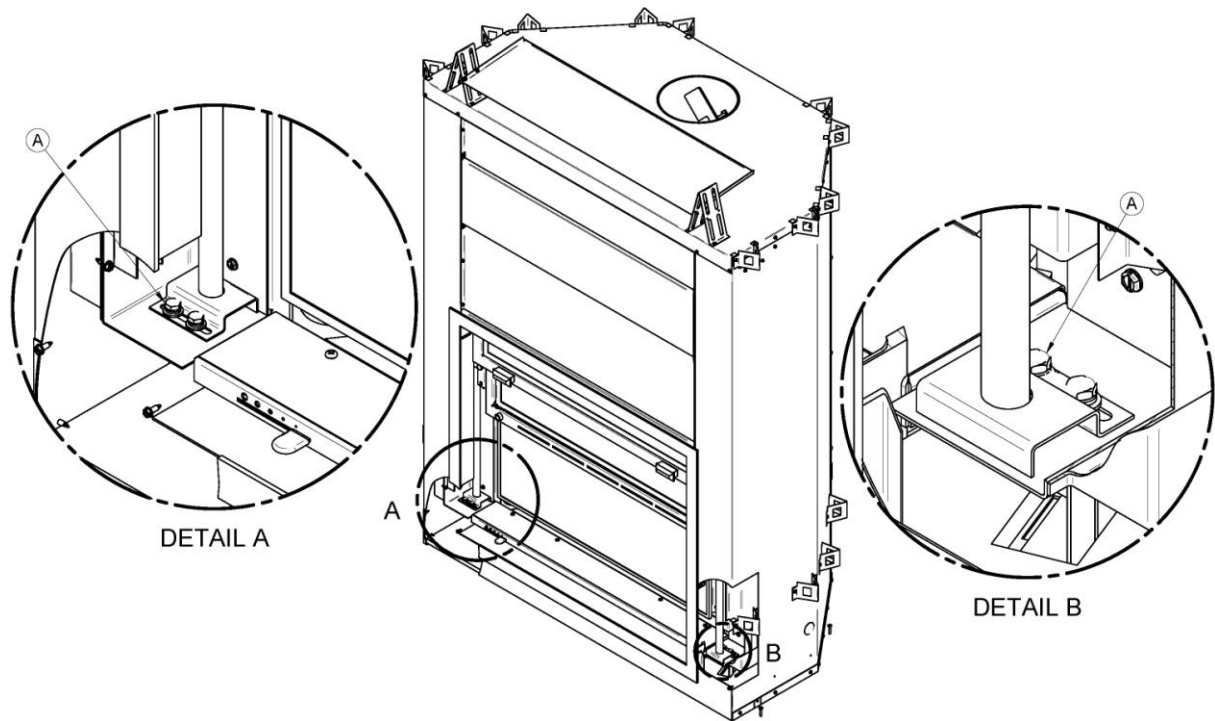

Figure 29

4.0 Venting System (Chimney and Chimney Connector)

4.1 General

The venting system is the engine that drives your wood heating system. Even the best fireplace will not function safely and efficiently as intended if not connected to a suitable chimney.

The heat in the flue gases that pass from the fireplace to the chimney is not wasted heat. This heat is what the chimney uses to make the draft that draws in combustion air and keeps the combustion gases within the fireplace. You can think of heat in the flue gas as the fuel the chimney uses to make draft.

4.2 *Suitable Chimneys*

This wood fireplace may be connected to either a factory-built metal or a masonry chimney. Whether metal or masonry, the chimney must have a number of characteristics to be suitable. To be suitable, a factory-built metal chimney must comply with UL 103HT (U.S.A.), ULC S629 (Canada) or ULC S-604 (Canada). Factory-built chimneys are tested as a system with all the necessary components for installation. The instructions provided with the chimney by its manufacturer are the only reliable source of installation guidelines. To be safe and effective, the chimney must be installed exactly in accordance with the manufacturer's instructions. **Use only components intended for the brand and model of chimney you are using. Never substitute parts from other chimney brands or build your own components.**

This wood fireplace is to be connected to a chimney with an 8" diameter flue passage.

The fireplace may also be connected to a masonry chimney, provided the chimney complies with the construction regulations found in the building code enforced locally. The chimney must have either a clay liner or a suitably listed stainless steel liner. If the masonry chimney has a square or rectangular liner that is larger in cross sectional area than a round 8" flue, it should be relined with a suitably listed 8" stainless steel liner. Do not downsize the flue to less than 8" unless the venting system is straight and exceeds 25 feet in height.

TABLE 1 - LISTED CHIMNEYS FOR YOUR FP7LM ANTOINETTE WOOD FIREPLACE

CHIMNEY MANUFACTURER	BRAND	TYPE	INNER DIAMETER
Selkirk	Ultra-Temp (UT)	1" Solid Pack	8" (20 cm)
Selkirk	Super Pro (SPR)	1" Solid Pack	8" (20 cm)
Selkirk	Super Vent (JSC)	1" Solid Pack	8" (20 cm)
Selkirk	Hart & Cooley (TLC)	1" Solid Pack	8" (20 cm)
Selkirk	Sure-Temp (ST)	1" Solid Pack	8" (20 cm)
Selkirk	CF Sentinel (CF)	2" Solid Pack	8" (20 cm)
Selkirk	Super Pro 2100 (ALT)	2" Solid Pack	8" (20 cm)
Selkirk	Super Vent 2100 (JM)	2" Solid Pack	8" (20 cm)
Selkirk	UltimateOne	1" Solid Pack	8" (20 cm)
Security Chimney	ASHT+	1" Solid Pack	8" (20 cm)
Security Chimney	S-2100 +	2" Solid Pack	8" (20 cm)
Simpson Dura Vent	Dura Tech	1" Solid Pack	8" (20 cm)
Simpson Dura Vent	Dura Plus HTC	2" Solid Pack	8" (20 cm)
ICC	Excel 2100	1" Solid Pack	8" (20 cm)
Metal Fab	Temp Guard	1" Solid Pack	8" (20 cm)
Olympia Chimney	Ventis	1" Solid Pack	8" (20 cm)

WARNING: IF THE MALE NOZZLE "HATCHED AREA (A)" OF THE ANCHOR PLATE EXCEEDS 2" (51 MM) IN LENGTH (VALUE (X), SEE IMAGE BELLOW), IT SHALL BE CUT ABOVE THE LIFTING HOOKS WELDED TO THE INSIDE OF THE FLUE OUTLET SO THAT THE ANCHOR PLATE RESTS PERFECTLY ON TOP OF THE FIREPLACE.

CAUTION: IF THE FLUE OUTLET IS CUT ONLY AROUND THE HOOKS, MAKE SURE THAT THE FLUE DAMPER MECHANISM WORKS PROPERLY BEFORE CLOSING THE WALLS.

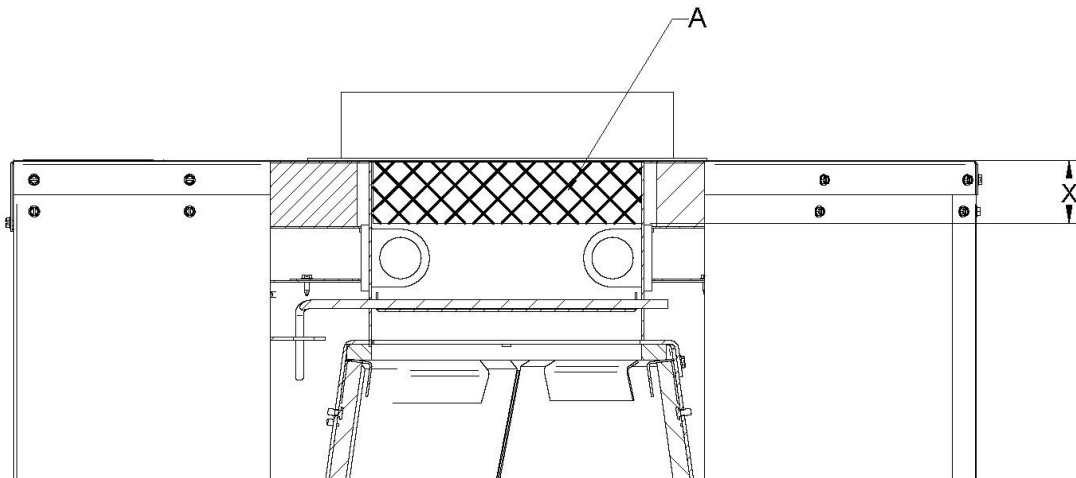

TABLE 2 – LIST OF MANDATORY COMPONENTS

CHIMNEY MANUFACTURER	MANDATORY COMPONENTS	TYPE/BRAND
Selkirk	<ul style="list-style-type: none"> Ventilated roof flashing 	2" Solid Pack: SuperVent 2100 (JM), Super Pro 2100 (ALT), Sentinel (CF)
ICC	<ul style="list-style-type: none"> Ventilated roof flashing 	1" Solid Pack: Excel 2100
Cheminée Sécurité	<ul style="list-style-type: none"> Ventilated roof flashing 	2" Solid Pack: S-2100
Simpson Dura-Vent	<ul style="list-style-type: none"> Ventilated roof flashing 	2" Solid Pack: Dura Plus HTC

4.3 Chimney Installation Notes

1. If possible, install an interior chimney as it will provide better performance. In areas with continuous temperatures below -18°C (0°F), the use of an exterior chimney increases the likelihood of operating problems such as low draft, high rate of creosoting, and poor start-up characteristics. Exterior chimneys are also prone to down-drafting and flow reversal. Installations, which are located on lower floors in the house, such as in a basement, in combination with outside chimney, are especially prone to flow reversal.
2. The FP7LM ANTOINETTE is listed only with chimney systems described in table 1.
3. A chimney venting a fireplace shall not vent any other appliance.
4. The minimum chimney system height for a straight installation is 15 ft. (4.6 m) including the height of the fireplace itself.
5. All chimney installations must include at least one support. Reducing the amount of chimney weight on the fireplace will help avoid the noise created when the fireplace expands. This can be achieved by having the chimney supported by the supports. The maximum chimney length that should be supported by the fireplace is 9 ft. (2.75 m) for 2" Solid Pack Chimney and 12 ft. (3.7 m) for 1" Solid Pack Chimney.
6. The chimney must extend at least 3 ft. (92 cm) above its point of contact with the roof and at least 2 ft. (61 cm) higher than any wall, roof or building within 10 ft. (3.1 m) of it. See **Figure 30a and 30b** to determine the configuration that applies to your roof (flat or sloped roof and the distance between the chimney and the highest point of the roof and/or the nearest chimney).
7. Deviations should be avoided whenever possible, especially the most pronounced. Each deviation adds some restriction to the chimney system and may lead to draft problems.
8. If the chimney extends higher than 5 ft. (1.5 m) above its point of contact with the roof, it must be secured using a roof brace.
9. A rain cap must be installed on top of the chimney. Failure to install a rain cap may cause corrosion problems.
10. Cut and frame square holes in all floors, ceilings, and roof that the chimney will go through to provide a 2" (50 mm) minimum clearance between the chimney and any combustible materials. Do not fill this 2" space with insulation or any other combustible material.
11. Portions of the chimney which may extend through accessible spaces must be enclosed to avoid contact with combustible materials or damage the chimney.

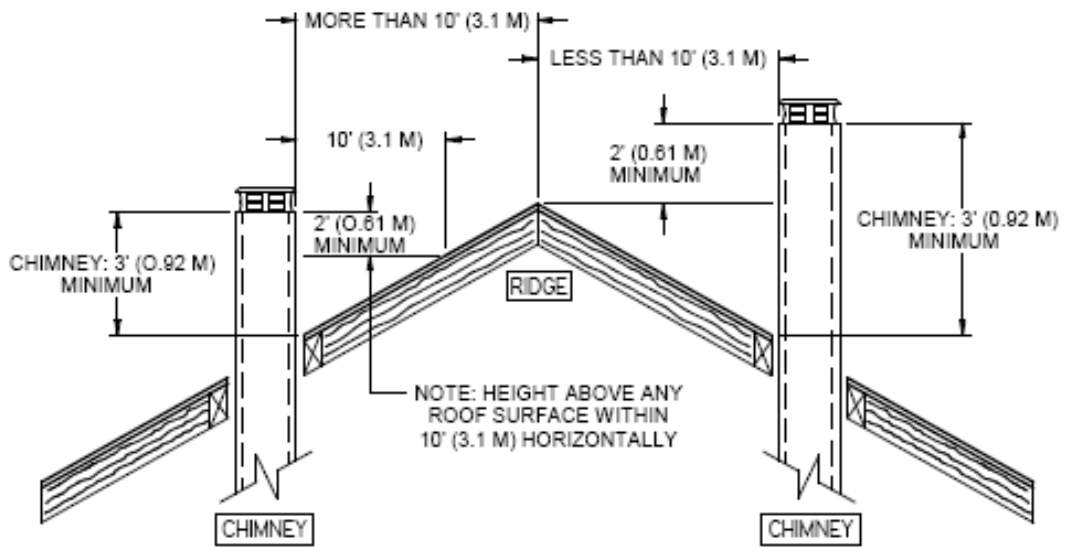

Figure 30a

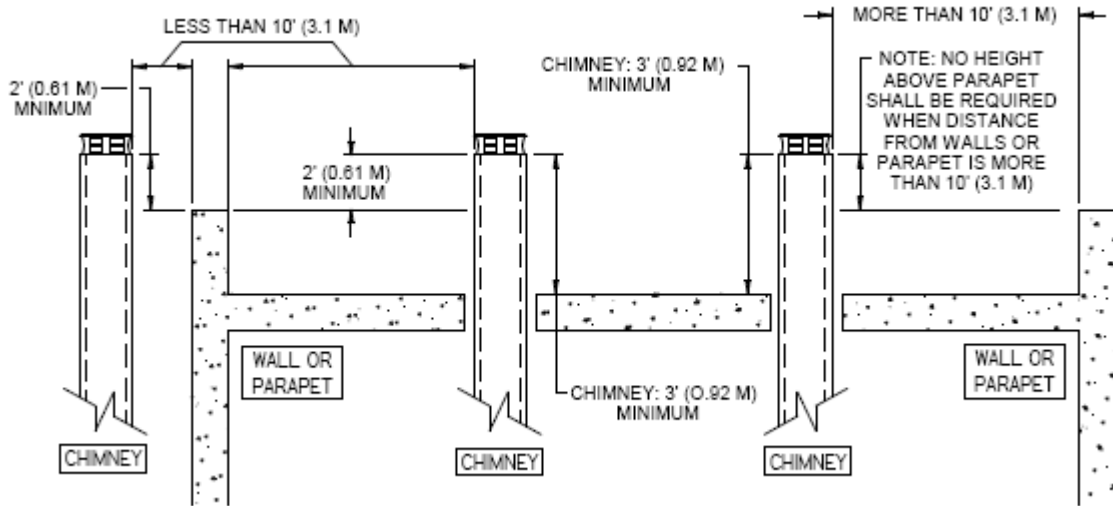

Figure 3b

12. When you build a chase enclosure for chimney sections above the roof, the chimney must extend at least 3 ft. (92 cm) above the chase enclosure and at least 2 ft. (61 cm) higher than any wall, roof or building within 10 ft. (3.1 m) of it. See **Figure 31a** and **31b** to determine the configuration that applies to your roof (flat or sloped roof and the distance between the chimney and the highest point of the roof and/or the nearest chimney).

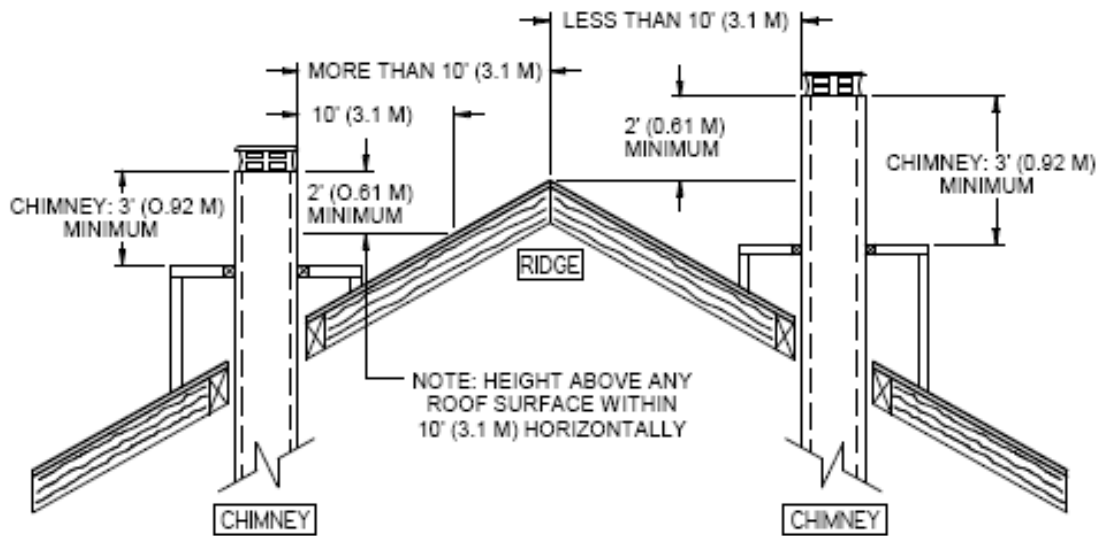

Figure 31a

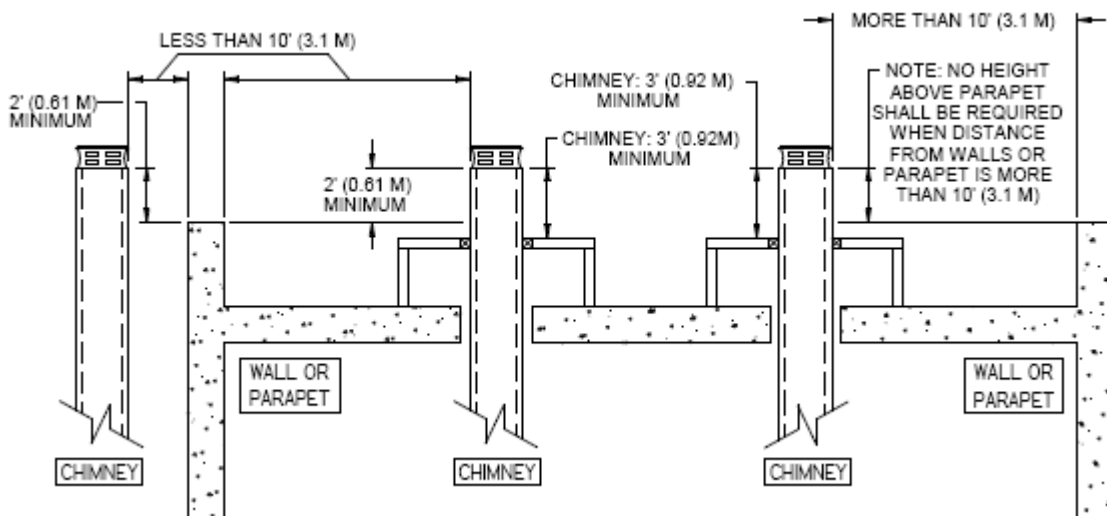

Figure 31b

4.4 Chimney Installation Instructions

1. Cut and frame the holes in the ceiling, floor and roof where the chimney will pass. Use a plumb bob to line up the center of the holes. Make sure that the size of the floor and ceiling holes are in accordance with the chimney manufacturer's instructions.

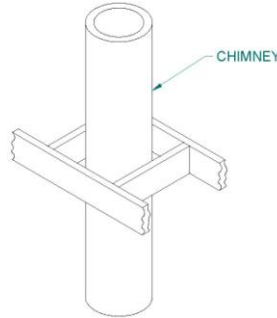

Figure 32

2. From below, install a firestop supplied by the chimney manufacturer in each ceiling/floor separation through which the chimney will pass. At the attic level, install an attic radiation shield from above (see Figure 33).
3. Follow the chimney's manufacturer's instructions and place the first chimney length on the fireplace. For all chimneys, you must use an anchor plate supplied by the chimney manufacturer before installing the first chimney length (see Figure 33). Continue installing chimney lengths making sure to lock each length in place according to the chimney manufacturer's instructions. In many cases, it is recommended to secure connections with three (3) ½" (12 mm) metal screws.
4. Every time the chimney passes through a ceiling or a wall, install the appropriate firestop. When you reach the desired height, install the roof support. (Refer to instructions included with the support).
5. Then, put the roof flashing in place and seal the joint between the roof and the flashing with roofing pitch (see Figures 33). For sloping roofs, place the flashing under the upper shingles and on top of the lower shingles. Nail the flashing to the roof, using roofing nails.
6. Place the storm collar over the flashing, and tighten it with the bolt supplied. Finally, seal the joint between the storm collar and the chimney, using silicone caulking.
7. Install the chimney cap.
8. When a ventilated roof flashing is installed, precautions are to be taken not to caulk or seal the ventilating openings.

EXAMPLE OF TYPICAL CHIMNEY INSTALLATION

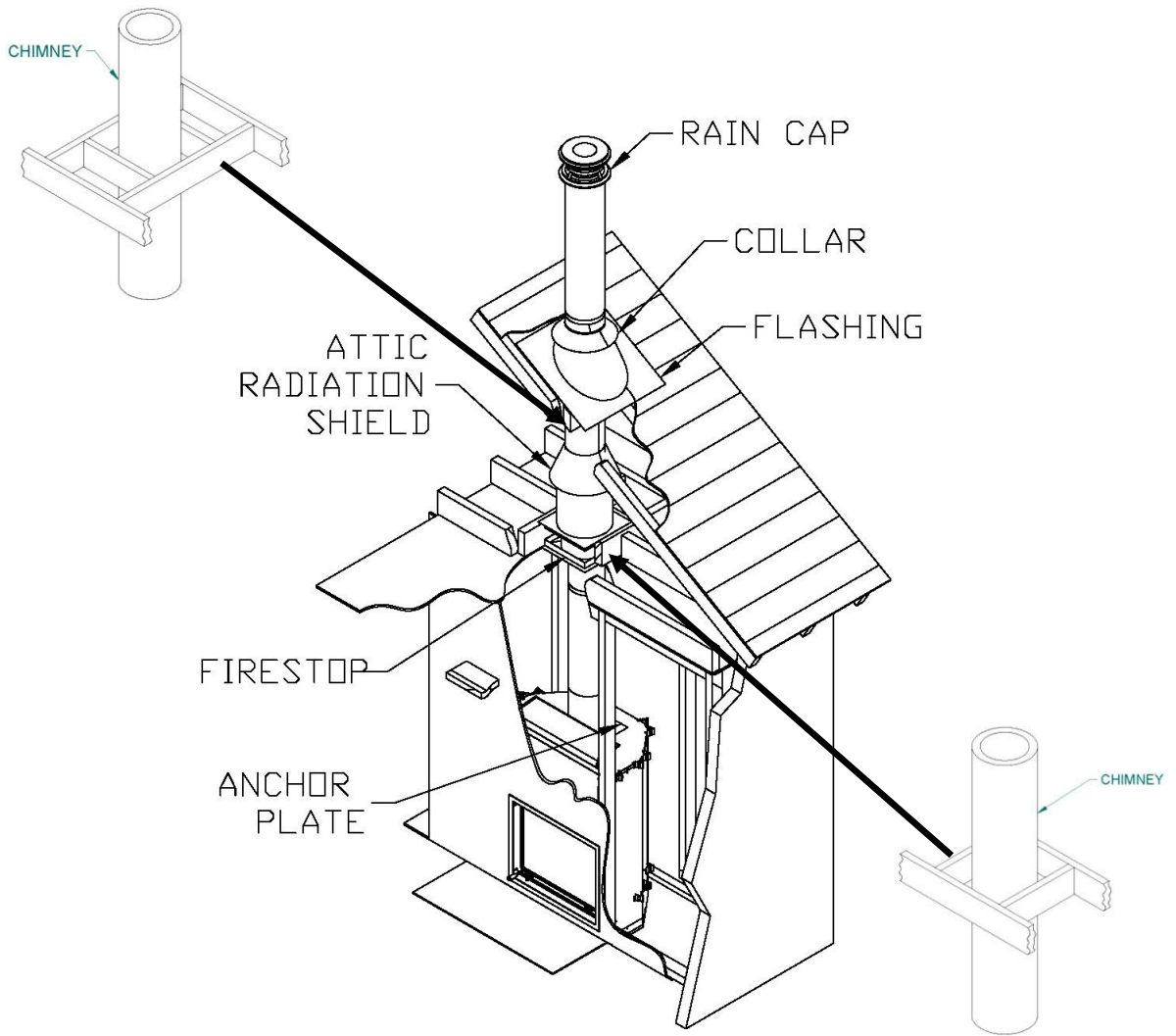

Figure 33

**TABLE 3 – THE MINIMUM SYSTEM HEIGHT
WHEN USING ELBOWS IS:**

Fireplace model	FP7LM ANTOINETTE WOOD FIREPLACE
Chimney model	All models listed in Table 1
Vertical installation	15 ft. (4.6 m)*
Two (2) elbows	20 ft. (6.1 m)*
Four (4) elbows	20 ft. (6.1 m)*

*Including the height of the fireplace itself.

After reaching the location requiring the elbow, proceed as follows:

1. Install the first elbow; turn it in the required direction. Secure it to the chimney according to the chimney manufacturer's instructions. In many cases, it is recommended to secure connections with three (3) ½" (12 mm) metal screws.
2. Install the necessary chimney lengths to achieve the required offset. Lock the chimney lengths together according to the chimney manufacturer's instructions. In many cases, it is recommended to use three (3) ½" (12 mm) metal screws. If the offset length is made of two (2) chimney lengths or more, many chimney manufacturers may require that you use an offset or roof support halfway up the offset. If penetrating a wall, install a wall radiation shield supplied by the chimney manufacturer (see Figures 34 & 35).
3. Use another elbow to turn the chimney vertically. Secure the elbow.
4. Use a plumb bob to line up the centre of the hole. Cut a hole for the chimney in the ceiling/floor. Frame this hole as described previously.
5. From below, install a firestop supplied by the chimney manufacturer (see Figure 32).
6. A support must be used on the first 15' section (4.6 m).
7. Continue with the regular installation.

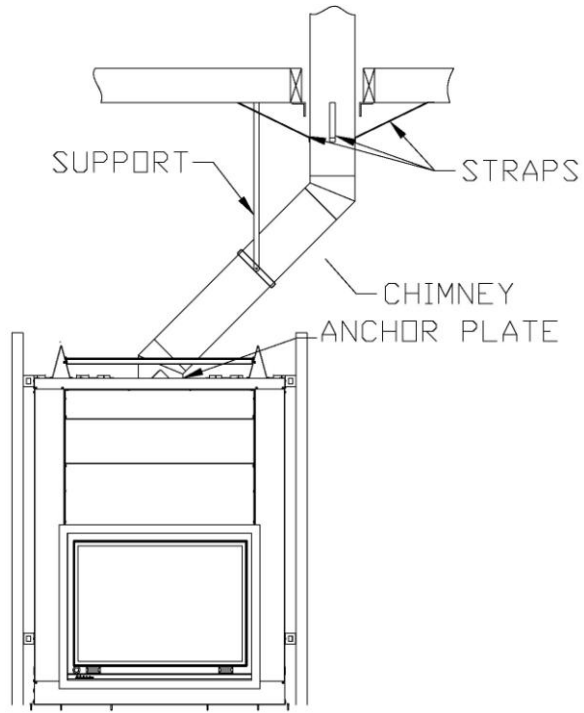

Figure 34

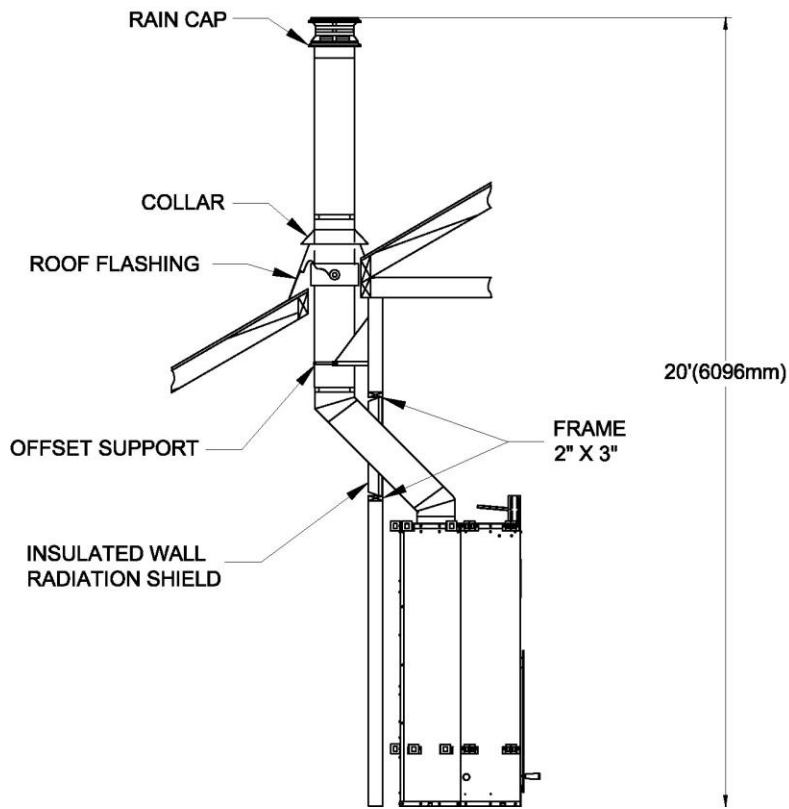

Figure 35

4.6 *Angled Radiation Shield*

When passing through a combustible wall with the chimney at a 30° or 45° angle (30° or 45° in Canada and 30° only in the USA), an angled radiation shield provided by the chimney manufacturer must be installed. Only one is required. Follow the chimney manufacturer's installation instructions.

In cold climate locations, it is recommended that you use the insulated wall radiation shield since it will maintain the home's thermal barrier.

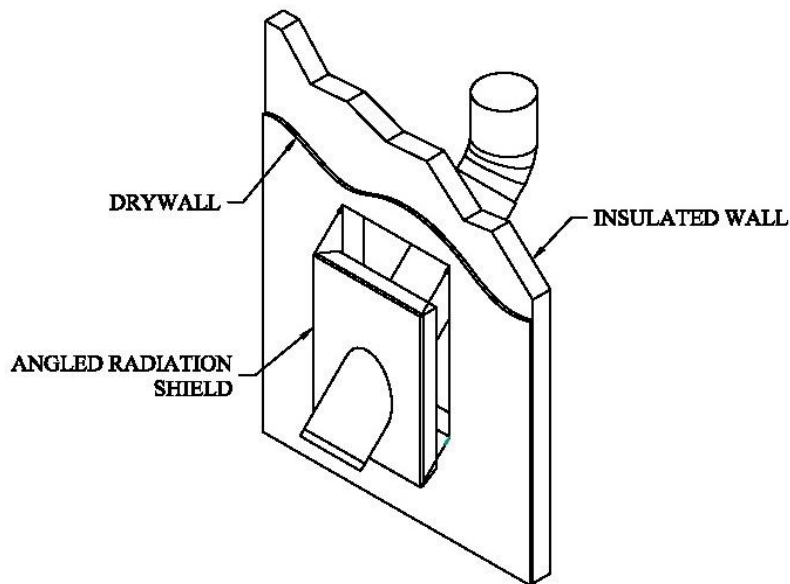

Figure 36

4.7 *Chimney Support Installation*

4.7.1 Universal Roof Support

This support has three possible uses:

1. It must be used on a roof to support the chimney.
2. It may be used on a floor, ceiling or roof above an offset to support the chimney above the offset.
3. It may be used on a floor, ceiling or roof as a supplementary support.

For roof support installation, refer to the instructions provided with the support by the chimney manufacturer. Many manufacturers will provide the maximum height of chimney that can be supported by the support. Make sure you respect those parameters.

4.7.2 Universal Offset Support

This support is used to support the chimney above an offset. When the chimney offset is used to pass through a wall, this support may be used on the wall to support the chimney. For offset support installation, refer to the instructions provided with the support by the chimney manufacturer. Many manufacturers will provide the maximum height of chimney that can be supported by the support. Make sure you respect those parameters.

4.8 Chimney Chase and Multiple Terminations

For the purpose of this manual, a chimney chase is considered a part of the chimney system rather than part of a building.

For installations where more than one chimney is located in the same chase or within the same area, we suggest that their terminations be separated by at least 16" (410 mm) horizontally, and 18" (460 mm) vertically. This separation is to prevent smoke migrating from one chimney to another (see Figure 37).

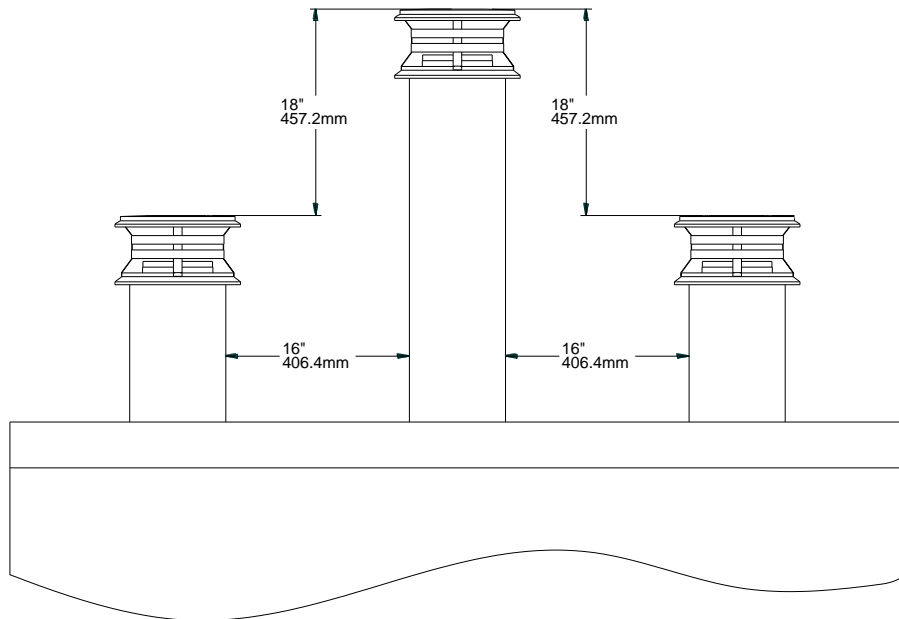

Figure 37

4.9 Installation Instructions for Masonry Application

WARNING: BEFORE STARTING THE INSTALLATION, THE MASONRY CHIMNEY MUST BE INSPECTED BY A QUALIFIED CHIMNEY SWEEPER.

The following requirements must be respected:

1. The chimney must be absolutely clear of any soot residue or creosote. Check for cracks, loose or missing bricks that could inhibit correct installation of the liner.
2. The clearance to combustible material must be a minimum of 1" between the outside of the masonry and any wood framing or loose insulation.
3. The chimney must be built in accordance with the current building code.
4. No other appliance can be connected to the same chimney.

Installation:

The chimney must be relined with a stainless steel liner of the same diameter as the outlet of the fireplace. For connection at 30° or 45° angle, a special connector must be used to connect the liner to the insulated chimney. Verify availability and installation instructions for this connector with the chimney manufacturer.

Follow these steps:

1. Position the fireplace in its location. Temporarily install the elbow on the top of the fireplace and, using a level, mark with an oval the location where the flue liner will enter the masonry chimney.
2. In the middle of the oval, drill a hole in the masonry chimney at 45° or 30°.
3. Increase the size of the hole until a 45° or 30° liner elbow can be easily slipped through.
4. Slide the liner down from the top of the masonry chimney until you reach the hole level.
5. Slip through the hole a 45° or 30° liner elbow and connect it to the liner.
6. Add a small liner section to the liner elbow which will allow the liner to extend at least 12" (measured at the top of the liner) from the masonry chimney.
7. Seal the opening around the liner with high temperature refractory cement
8. Then, follow the chimney manufacturer's instructions to connect the extended liner section to the special chimney connector.

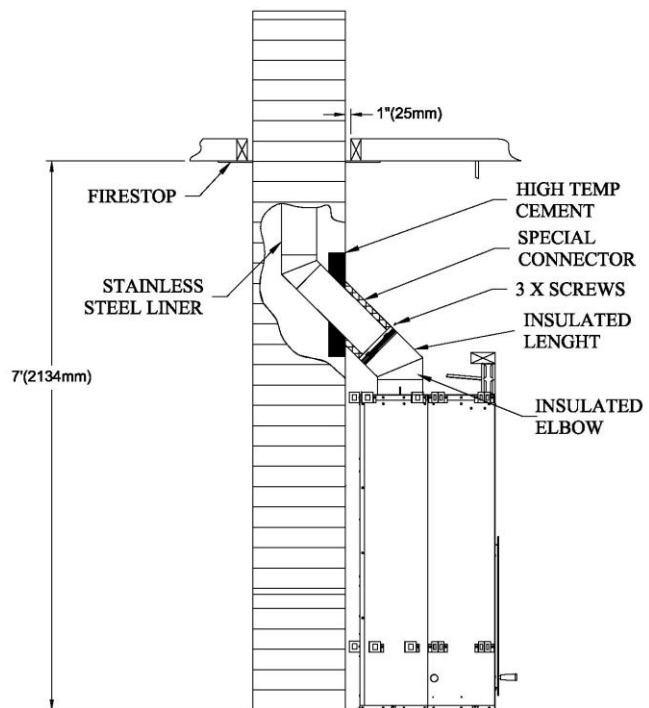

Figure 38

PART B - OPERATION AND MAINTENANCE

5.0 Fuel

The FP7LM ANTOINETTE WOOD FIREPLACE is designed to work best when fuelled with seasoned cordwood. Use solid wood or processed solid fuel fire logs only. Hardwoods are preferred to softwoods since the energy content of wood is relative to its density. Hardwoods will result in a longer burning fire and less frequent refuelling. A moisture content of 15% to 20% (seasoned) is recommended. Wood that has been cut and split and let to dry under a cover for a period of one year will usually meet those criteria. Excessively wet wood will be difficult to burn and will result in lower efficiency, increased creosoting and deposits on the glass and in the chimney. Excessively dry wood will burn well but will also have higher emissions and shorter burning time.

Do not burn scrap or garbage, treated wood or wood such as driftwood from the ocean which has been exposed to salt or other chemicals. Salt or chemicals can corrode the firebox and chimney. Do not burn large amounts of paper, cardboard, Christmas tree branches or building construction materials. Intense firing with these materials may overheat the fireplace, causing damage to the unit, a home fire or even possibly igniting a chimney fire if the chimney is creosoted.

CAUTION: DO NOT OVER FIRE THIS HEATER OVER FIRING CAN RESULT IN A SAFETY HAZARD AND CAN PERMANENTLY DAMAGE THE FIREPLACE AND CHIMNEY.

5.1 *The Use of Manufactured Logs*

There are numerous types of manufactured logs sold on the market. You must be very careful with this type of product. Many brands of manufactured logs contain chemical additives. **DO NOT BURN ANY MANUFACTURED LOGS CONTAINING CHEMICAL ADDITIVES. IF YOU DO, YOU MAY OVERHEAT YOUR FIREPLACE, THEREFORE CAUSING A FIRE HAZARD AND VOIDING YOUR WARRANTY.** Manufactured logs made of 100% wood residues do not pose a threat to your fireplace. However, they must be used carefully. Manufactured logs typically release a much larger heat output over a short period of time. Therefore, you cannot place a large quantity of such logs into your fireplace. Start with one log and see how the fireplace reacts. You can increase the number of logs burned at a time to a maximum of three. Burning more than three manufactured logs at one time can overheat and damage your stove.

WARNING: DO NOT POKE OR STIR THE LOGS WHILE THEY ARE BURNING. USE ONLY FIRELOGS THAT HAVE BEEN TESTED FOR USE IN FIREPLACES (SEE ULC/ORD-C127, COMPOSITE FIRELOGS) AND PRIOR TO USE, REFER TO FIRELOG WARNINGS AND CAUTIONS MARKINGS ON PACKAGING.

6.0 OPERATING THE FP7LM ANTOINETTE WOOD FIREPLACE

Inside the firebox of your unit, you will find the handle that allows you to open the glass door of your fireplace. Simply insert into the opening provided for this purpose at the bottom left of the glass door. This handle is removable so you can take it off at your convenience.

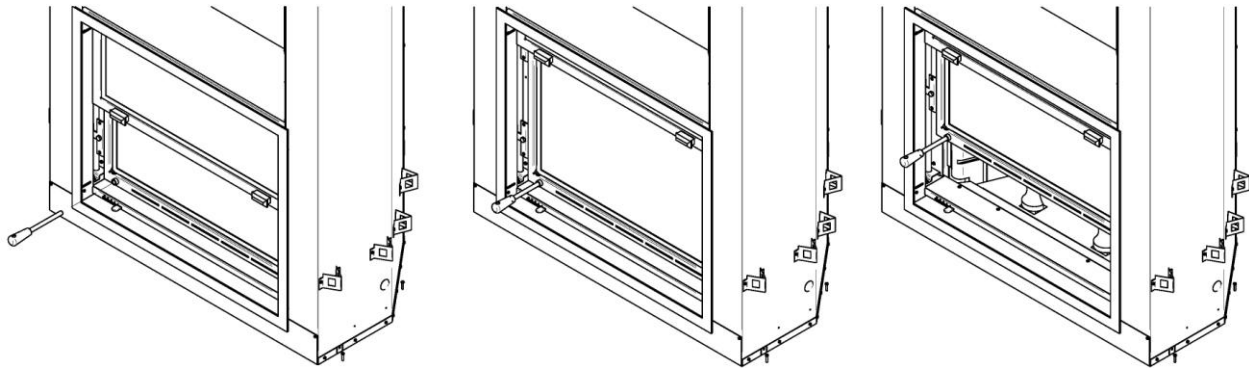

6.1 *First Fires*

The fresh paint on your fireplace needs to be cured to preserve its quality. Once the fuel load is properly ignited, only burn small fires in your fireplace for the first four hours of operation. Make sure that your exhaust damper and air intake control are in the open position. Make sure that there is enough air circulation while curing the fireplace. Open one or more windows as necessary. The odours can be smelled during the 3 or 4 first fires.

6.2 *Building a Fire*

To start a fire, place several crumpled up balls of newspaper in the firebox behind the andiron. Place small dry pieces of kindling on top of the paper, criss-crossing the kindling so that there are air spaces in between. Open the exhaust damper fully and light the newspaper. Once the newspaper and the kindling are well ignited, you may close the glass door for a few minutes so that the firebox and chimney of your fireplace can heat up enough for optimal operation. When this heating period is done and the kindling fire is well established, you can operate the fireplace with the firescreen or the glass door depending on your preference and add cordwood as needed.

The unit will burn best with 2-3 pieces of cordwood spaced 1 to 2 inches apart and allowing air to get under the fuel. Criss-crossing or arranging the fuel so that air can get underneath, will help the fire to get started easily.

CAUTION: THE EXHAUST DAMPER AND THE AIR INTAKE CONTROL MUST BE KEPT FULLY OPEN UNTIL THE FIREPLACE HAS COOLED DOWN FOR A FEW HOURS.

WARNING: NEVER PUT CORDWOOD IN FRONT OF THE ANDIRONS.

WARNING: THIS FIREPLACE IS NOT CERTIFIED FOR USE WITH A GAS LOG LIGHTER. SUCH A DEVICE SHOULD THEREFORE NOT BE INSTALLED ON THE FIREPLACE.

CAUTION: NEVER USE GASOLINE, GASOLINE-TYPE LANTERN FUEL, KEROSENE, CHARCOAL LIGHTER FLUID OR SIMILAR LIQUIDS TO START OR “FRESHEN UP” A FIRE IN THIS FIREPLACE. KEEP ALL SUCH LIQUIDS AWAY FROM THE FIREPLACE AT ALL TIMES.

CAUTION: NEVER USE A GRATE OR ELEVATE FIRE. BUILD WOOD FIRE DIRECTLY ON HEARTH.

CAUTION: KEEP COMBUSTIBLE MATERIALS AT LEAST 48 INCHES AWAY FROM THE FRONT OF THE FIREPLACE OPENING.

6.3 *Maintaining the Fire*

Once the wood has been consumed (or partially consumed) and you have obtained a good bed of embers, you should reload the unit. In order to do so, proceed by opening the glass door or the screen door for you to have enough free space to reload safely.

Your FP7LM ANTOINETTE WOOD FIREPLACE will work best if a thick bed of hot embers is maintained in the bottom of the firebox and a minimum of two large pieces of seasoned fuel are added. Combustion efficiency is largely related to establishing a hot ember bed, and hot firebox temperatures. The quicker the fireplace and chimney (flue) get up to normal operating temperatures, the better. Use a poker to make an air channel in the embers below the wood. This will allow air to flow under the wood for a more efficient burn.

6.4 *Air Intake Control and Exhaust Damper*

The air intake control (dilution air) and exhaust damper should be in the closed position when there has not been any wood or embers in the fireplace for a few hours. This will minimize air leakage up the chimney.

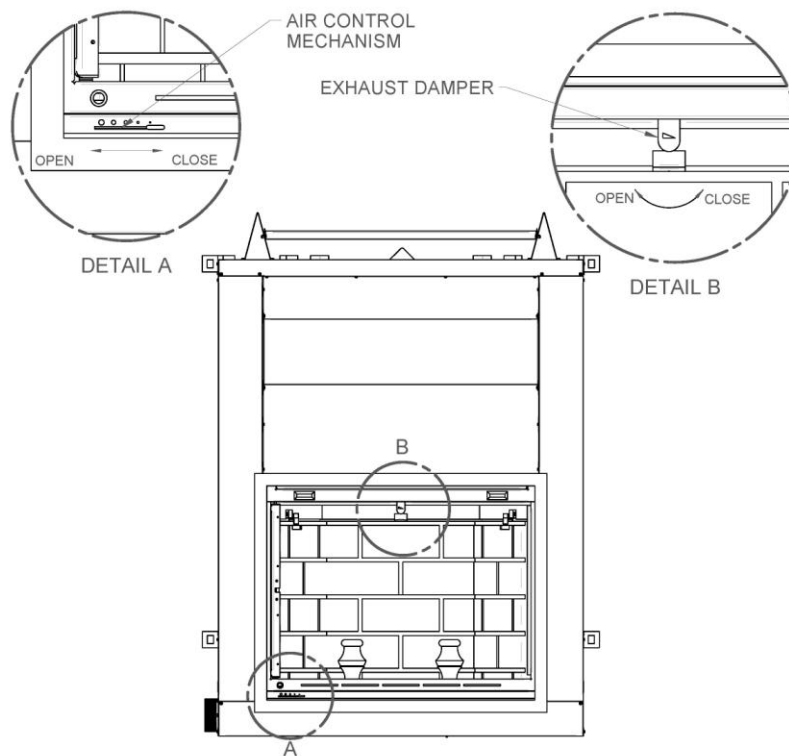

Figure 39

6.5 *Smoking – Causes and Troubleshooting*

Your fireplace has been designed and tested to provide smoke free operation. Occasionally, there may be a small amount of smoking upon lighting the fire, until the chimney heats up but this should not continue. If the fireplace continues to smoke it is probably for one of the following reasons:

A. Closed exhaust damper

Make sure that the exhaust damper is in the open position (see **Figure 39**).

B. Negative pressure in the house

As the fire burns, air goes up the chimney. This air must be replaced through leakage into the house or through the fresh air kit. When operating the FP7LM ANTOINETTE WOOD FIREPLACE, open a nearby window temporarily to check if there is adequate air supply replacement. If opening a window solves the problem, the house is under negative pressure.

C. Wet wood

Wet or tarred wood will smoulder and smoke instead of burning properly.

D. Dirty or blocked chimney

Check to make sure the chimney is clear and clean.

E. Chimney not long enough

The minimum system height is 15 feet (4.6m) including the height of the fireplace itself. The chimney must extend at least 3 feet (915 mm) above its point of contact with the roof and at least 2 feet (0.6 m) higher than any roof or wall within 10 feet (3 m) of it. When installed with offsets, the minimum system height is as per Table 3. Additional height will increase draft and will decrease the tendency to smoke. If only the minimum chimney height is installed, operating conditions must be optimal (interior chimney, start with an offset, etc.).

F. Poor chimney draft

With no fire, there should be sufficient draft to exhaust cigarette smoke introduced at the bottom of the throat. Chimneys installed against an outside wall without protection may generate back draft problems which will cause start-up problems. To prevent this, when you light a fire make sure you use small pieces of really dry wood and keep your glass door closed for the first 15 minutes. Reload your unit a few times with kindling before putting large pieces of cordwood.

IMPORTANT NOTES

- a. Do not block the hot air vents to the fireplace as this will cause the fireplace to overheat.
- b. Never start a fire using gasoline, kerosene, charcoal lighter fluid or any other combustible liquid.
- c. Do not burn coal. The sulphur in coal will corrode the firebox.
- d. Do not burn driftwood which has been in the ocean or salt water. The salt will corrode the firebox and chimney.
- e. Do not abuse the unit by burning paper or cardboard or construction material such as pressed wood, plywood or lumber.
- f. Do not allow the wood to smoulder or burn without flame, since this will produce excessive creosote in the unit.
- g. The exhaust damper and air intake control should be always in the open position when the fireplace is in use.

7.0 MAINTAINING YOUR FP7LM ANTOINETTE WOOD FIREPLACE

7.1 *Creosote – Formation and Need for Removal*

When wood is burned slowly without a flame, it produces tar and other organic vapours which combined with expelled moisture will form creosote. The creosote vapours condense in the relatively cool chimney flue of a slow-burning fire. As a result, creosote residue accumulates on the flue lining. When ignited this creosote makes an extremely hot fire. The chimney should be inspected at least twice a year during the heating season to determine if creosote build-up has occurred. When creosote has accumulated it must be removed to reduce the risk of a chimney fire.

7.2 *Chimney Maintenance*

Regular chimney inspection and maintenance combined with proper operation will prevent chimney fires. Keep your chimney clean. Do not allow more than 1/8" (3 mm) creosote build up in your chimney. The amount of creosote will depend on variables such as frequency of use and type of fires. We recommend that you:

- A. Initially inspect the chimney system weekly. From this, you will learn how often it will be necessary to clean your chimney.
- B. Have your chimney cleaned by a qualified chimney sweeper. If you wish to clean it yourself, we recommend using a stiff plastic or non-metallic brush. If a metal brush is used, its size should be slightly smaller than the flue to avoid damaging the chimney. Do not use a brush that will scratch the stainless steel interior of the chimney.
- C. Do not expect chemical cleaners to keep your chimney clean. The rain cap can be removed for inspection and/or cleaning of the chimney.

7.3 *Fire Baffles Removal Prior to Cleaning the Chimney*

Before starting to clean your chimney, we recommend that you remove the fire baffles to avoid creosote dust collection on top of the baffle. Follow the steps below to remove the fire baffle:

1. To remove the first fire baffle, move the piece towards the left and it will come off of its brackets. Figure 40.1
2. Put the baffle vertically in the fireplace to remove. Figure 40.2
3. To remove the second fire baffle, take it in your hands, move towards the front of the fireplace and it will fall from its brackets. Figure 40.3
4. Put the piece vertically to take out of the out of the fire box. Figure 40.4
5. You now have access to the chimney.

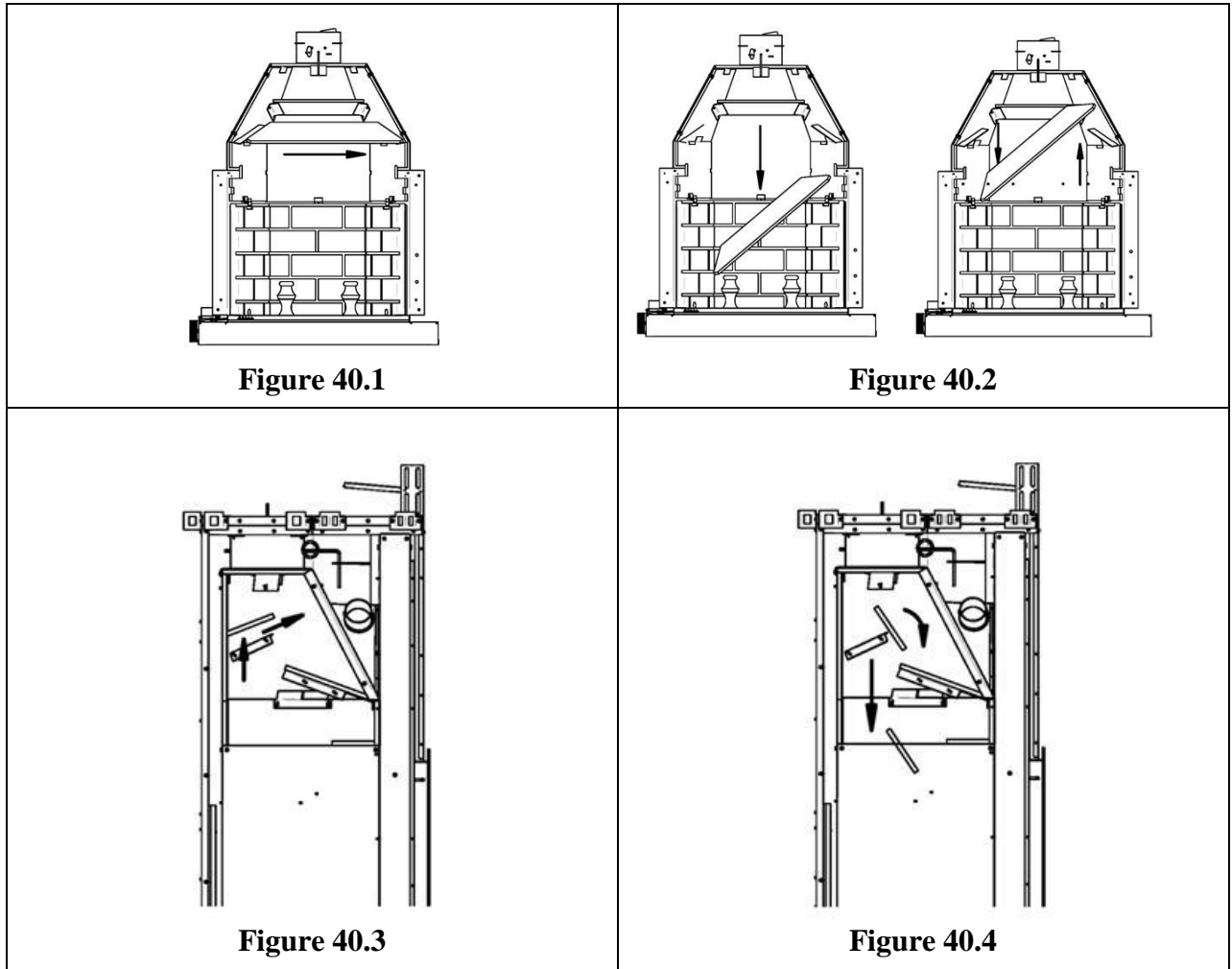

7.4 *Dealing With a Chimney Fire*

Regular chimney maintenance and inspection can prevent chimney fires. If you have a chimney fire, follow these steps:

1. Close the fireplace glass door and the exhaust damper;
2. Alert your family of the possible danger;
3. If you require assistance, alert your fire department;
4. If possible, use a dry chemical fire extinguisher, baking soda or sand to control the fire. Do not use water as it may cause a dangerous steam explosion;
5. Check outside to ensure that sparks and hot embers coming out of the chimney are not igniting the roof;
6. Do not use the fireplace again until your chimney and fireplace have been inspected by a qualified chimney sweeper or a Fire Department Inspector.

7.5 Disposal of Ashes

Ashes should be placed in a metal container with a tight fitting lid. The closed container of ashes should be placed on a non-combustible floor or on the ground, well away from combustible materials pending final disposal. If the ashes are disposed of by burial in soil or otherwise locally dispersed they should be retained in the closed container until all cinders have thoroughly cooled.

7.6 Refractory Panels Replacement

Do not use the fireplace with a broken or missing refractory panel.

Here are the steps to replace the refractory panels of your FP7 LM Antoinette fireplace:

1. Remove the Andirons (VA7070) by unscrewing the anchoring bolts. Figure 42.1
2. Remove the bottom refractory panel (22198). Figure 42.2
3. Unscrew the refractory panel retainers (2x: 1 left and 1 right) (PL64601). Figure 42.3
4. Remove the left and right side refractory panels (22195 and 22194). Figure 42.4
5. Remove the back refractory panels (22196 and 22197). Figure 42.5
6. To reinstall the replacement refractory panels, just follow the steps in reverse.

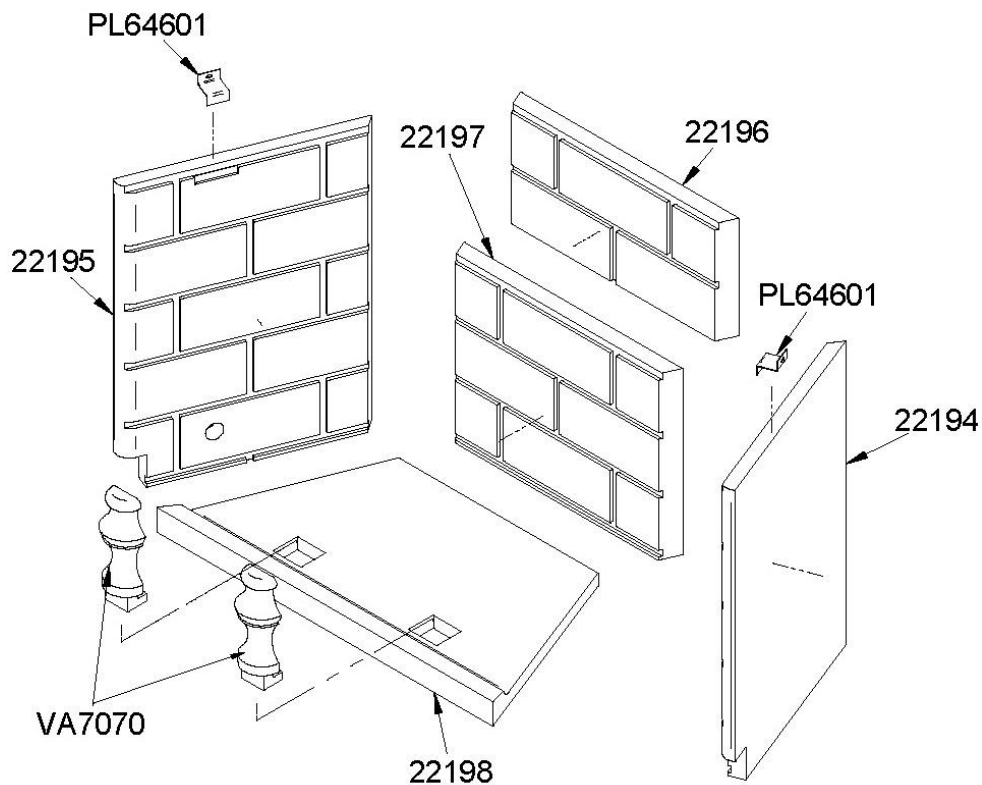

Figure 41: Replacing Antoinette refractory panels

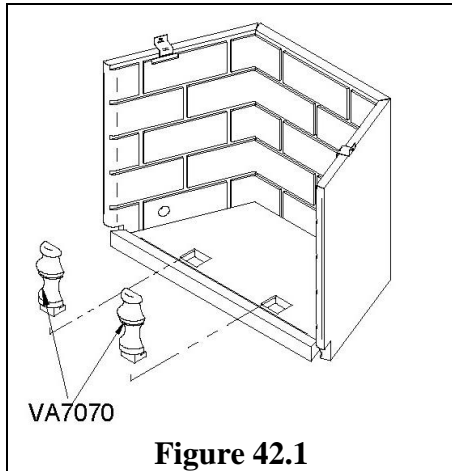

Figure 42.1

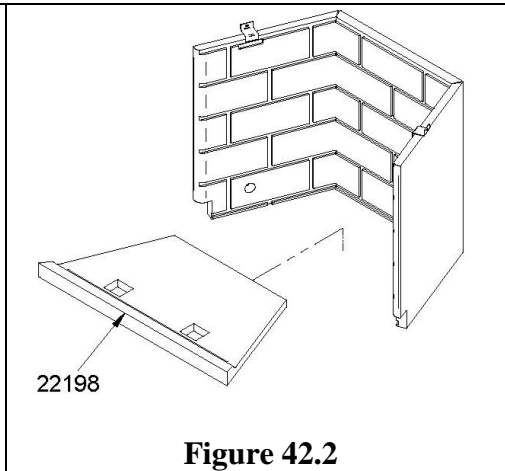

Figure 42.2

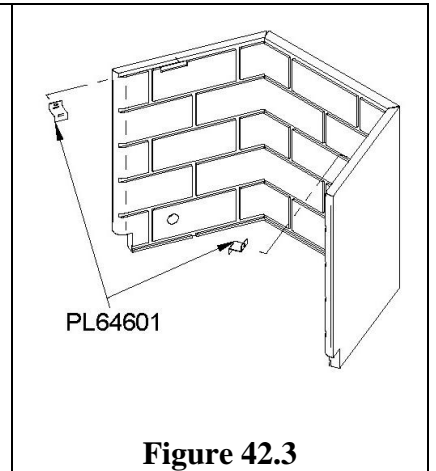

Figure 42.3

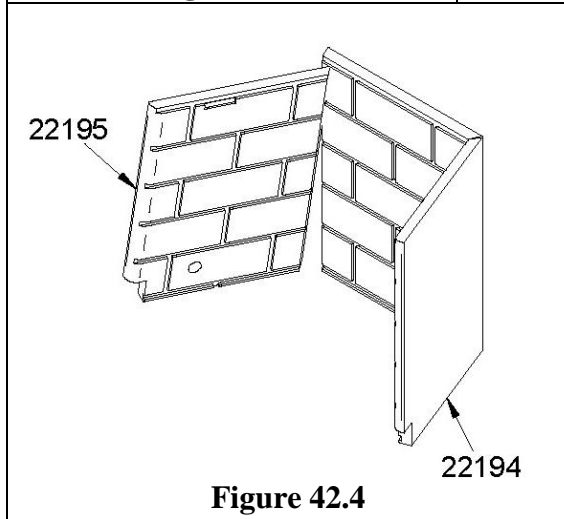

Figure 42.4

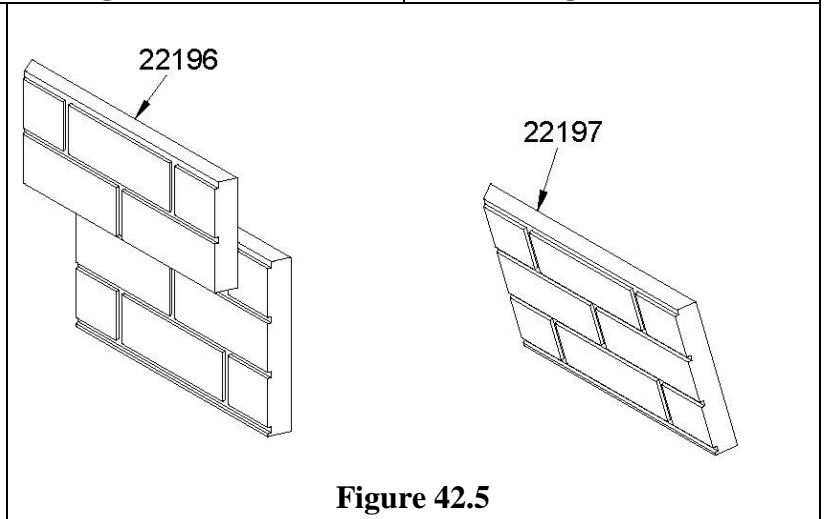

Figure 42.5

WARNING: DO NOT USE MATERIALS OTHER THAN THOSE LISTED IN THE REPLACEMENT PARTS SECTION DURING INSTALLATION AS THEY MAY BE SAFETY HAZARDS AND A FIRE COULD RESULT.

7.7 Glass Care – Replacement

The glass used in the FP7LM ANTOINETTE WOOD FIREPLACE is ceramic glass 5 mm thick having dimensions of: 30 3/4" x 20 3/4" and tested to reach temperatures up to 1400 °F. If the glass breaks, it must be replaced with one having the same specification. Contact your Valcourt dealer to obtain a genuine replacement part (see “replacement parts”, in appendix to get the proper part number).

WARNING: TEMPERED GLASS OR ORDINARY GLASS WILL NOT WITHSTAND THE HIGH TEMPERATURES OF THE FP7LM ANTOINETTE WOOD FIREPLACE.

WARNING: DO NOT ABUSE THE GLASS DOOR BY SLAMMING IT AGAINST THE FIREPLACE.

WARNING: DO NOT OPERATE THE FIREPLACE WITH A CRACKED OR BROKEN GLASS.

WARNING: DO NOT USE MATERIALS OTHER THAN THOSE LISTED IN THE REPLACEMENT PARTS SECTION DURING INSTALLATION AS THEY MAY BE SAFETY HAZARDS AND A FIRE COULD RESULT.

Here are the steps to replace the glass of your FP7LM Antoinette fireplace (Figure 43):

1. Open the glass door (A) with the lock located on right side of the glass door.
2. Remove all the rivets (C) holding the door.
3. Remove all debris from the frame.
4. Use only 3/16" (5 mm) ceramic glass.
5. Slide the new window into the frame (B) and fasten it in place with 1/8" pop rivet (C) through the glass retainers (D).
6. Handle the glass with care to avoid injury.

NOTE: Never use substitute parts. Use only Valcourt brand parts.

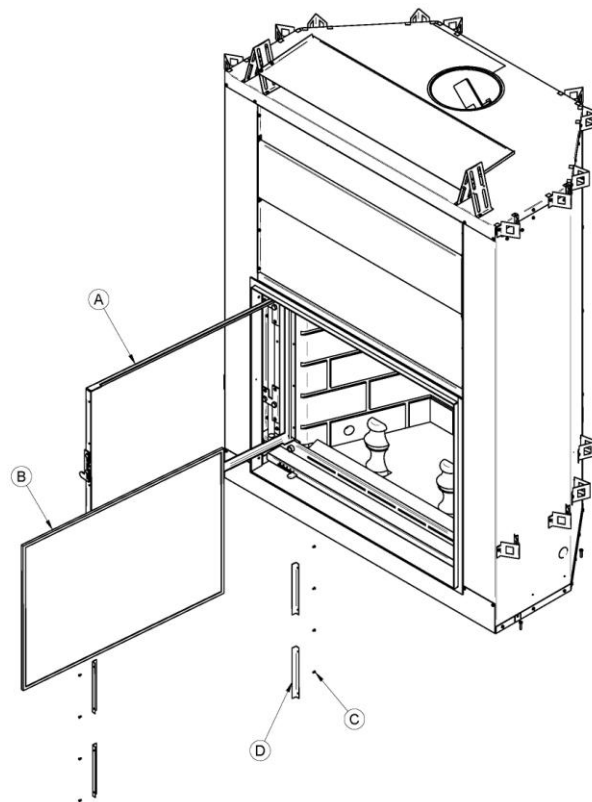

Figure 43

7.8 Glass Care – Cleaning

The FP7LM ANTOINETTE WOOD FIREPLACE is designed to keep the glass clean under normal operating conditions. To clean the glass, there are a number of specially designed cleaners. Your authorized Valcourt dealer can recommend a suitable cleaner which is available in your area. Regular household glass cleaners will not clean creosote and they usually contain ammonia that may stain the glass permanently.

WARNING: ONLY WASH THE GLASS WHEN IT'S COLD.

WARNING: DO NOT USE ABRASIVES SUCH AS STEEL PADS, STEEL WOOL OR OVEN CLEANER AS THEY WILL SCRATCH THE GLASS.

WARNING: DO NOT USE MATERIALS OTHER THAN THOSE LISTED IN THE REPLACEMENT PARTS SECTION DURING INSTALLATION AS THEY MAY BE SAFETY HAZARDS AND A FIRE COULD RESULT.

8.0 VIEWS WITH MEASUREMENTS

VA7FE06

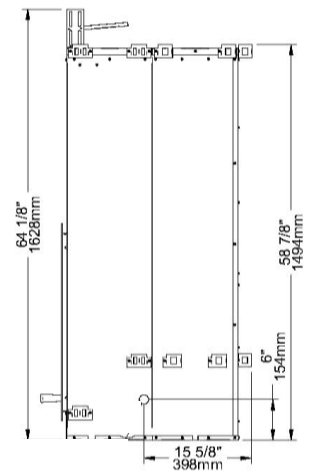
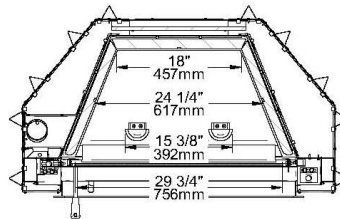
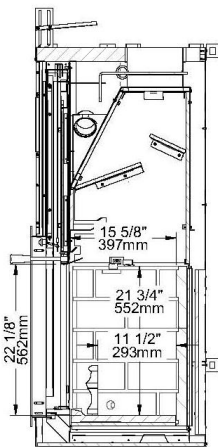
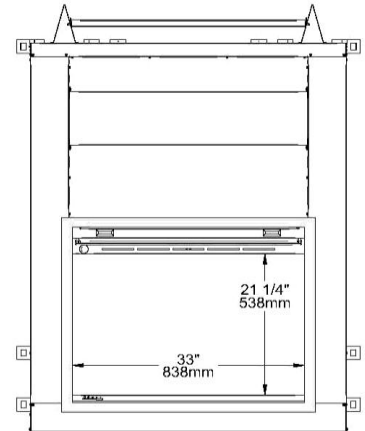
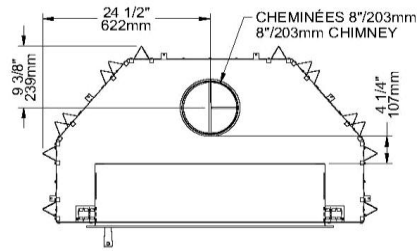
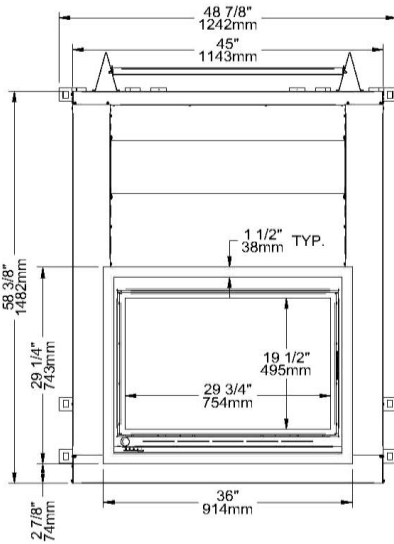
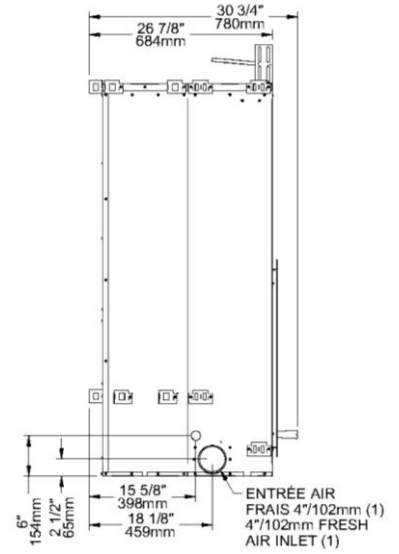
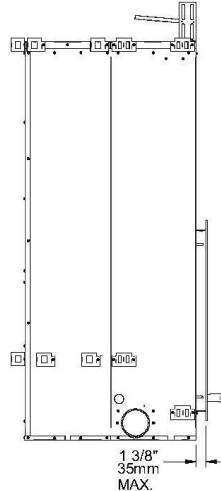
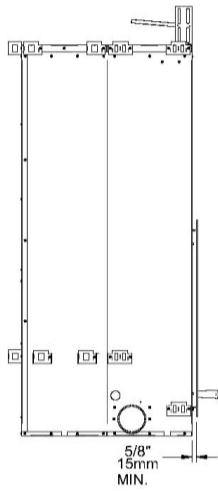

VA7TR

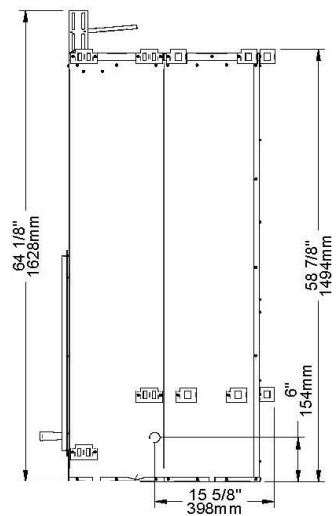
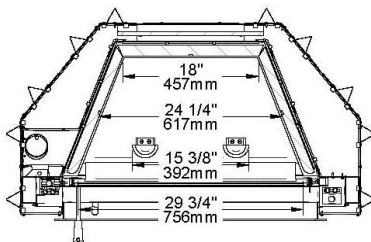
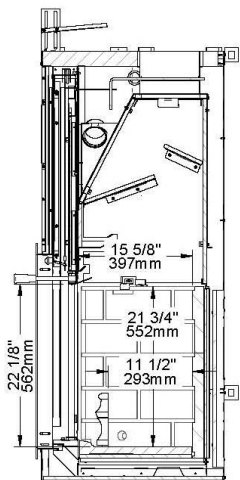
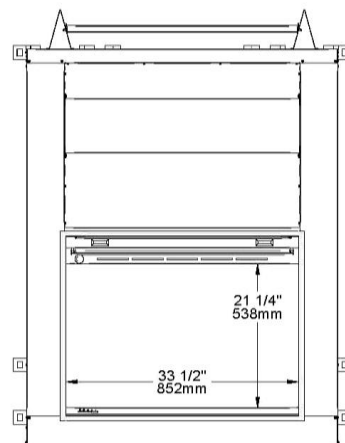
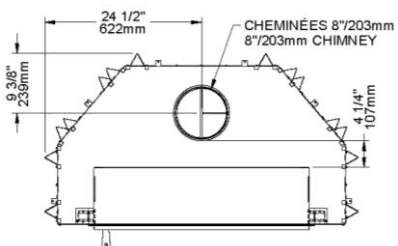
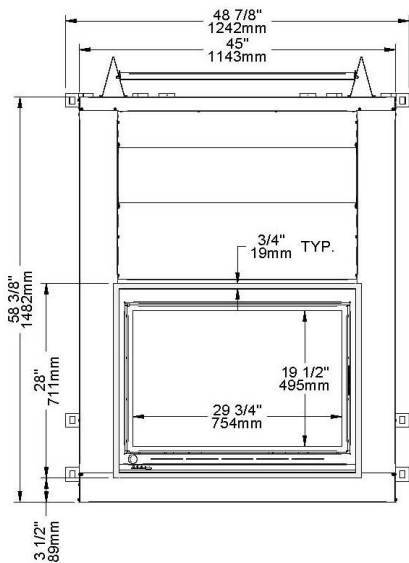
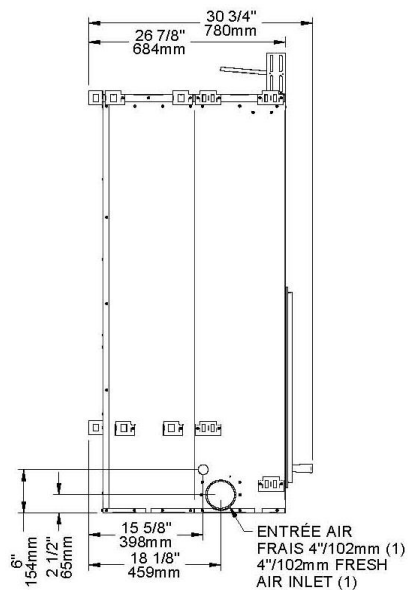
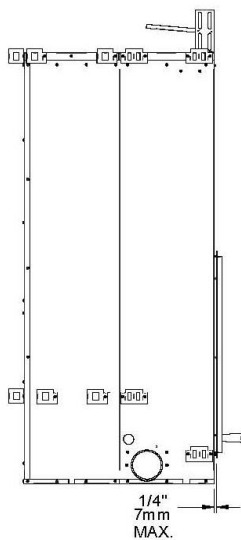
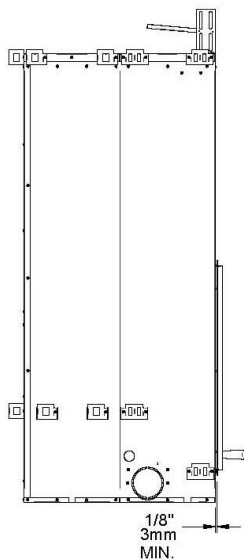

8.1 EXPLODED DIAGRAM AND PARTS LIST

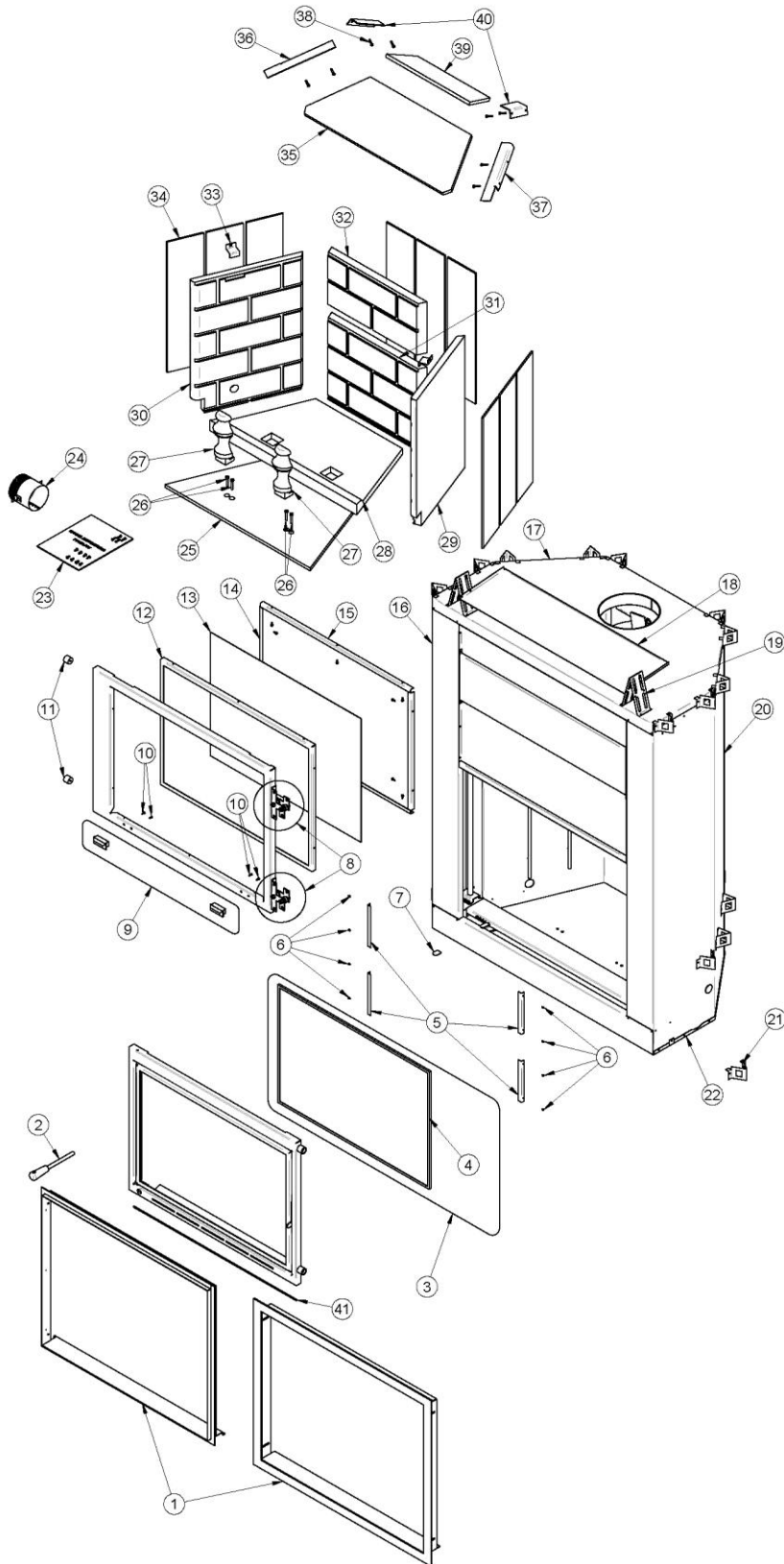

IMPORTANT: THIS IS DATED INFORMATION. When requesting service or replacement parts for your stove, please provide the model number and the serial number. We reserve the right to change parts due to technology upgrade or availability. Contact an authorized dealer to obtain any of these parts. Never use substitute materials. Use of non-approved parts can result in poor performance and safety hazards.

#	Item	Description	Qty
1	VA7FE06	NARROW OVERLAP	1
1	VA7TR	MASONRY TRIM	1
2	SE64628	REMOVABLE WOODEN HANDLE WITH ROD	1
3	VA7051J	CERAMIC GLASS WITH GASKET 3/16" X 20 5/8" X 30 5/8"	1
4	AC06400	3/4" (FLAT) X 6' BLACK SELF-ADHESIVE GLASS GASKET KIT	2
5	PL61086	GLASS RETAINER	4
6	30165	POP RIVET STEEL 1/8" X 17/64"	8
7	30556	AIR CONTROL FINISHING TIP	1
8	SE64520	ROLLING SUPPORT ASSEMBLY	2
9	AC09194	BLACK WOODEN DOOR HANDLE (2 PER PACKAGE)	1
10	30244	WOOD SCREW #8 X 3/4" PAN HEAD	4
11	30585	SLIDING DOOR GUIDE	2
12	PL64595	FIRESCREEN FRAME	1
13	PL64594	FIRESCREEN	1
14	PL64597	LEFT OR RIGHT SCREEN RETAINER	2
15	PL64596	TOP OR BOTTOM SCREEN RETAINER	2
16	99999	BUILD TO ORDER	1
17	99999	BUILD TO ORDER	1
18	PL64603	TOP HEAT SHIELD	1
19	PL64602	TOP SPACER	2
20	99999	BUILD TO ORDER	1
21	PL64626	LATERAL SPACER	20
22	99999	BUILD TO ORDER	1
23	SE45530	FP7LM INSTRUCTION MANUAL KIT	1
24	PL59765	4" ADAPTER FOR FRESH AIR INTAKE KIT	1
25	21353	C-CAST BOTTOM INSULATION 17 7/16" X 15 3/8" X 29 7/16"	1
26	30509	HEX BOLT 1/4-20 X 1 1/4" ZINC	4
27	VA7070	PAINTED CAST IRON ANDIRON	2
28	22198	BOTTOM REFRACTORY PANEL	1
29	22194	RIGHT REFRACTORY PANEL	1
30	22195	LEFT REFRACTORY PANEL	1
31	22197	REAR BOTTOM REFRACTORY PANEL	1
32	22196	REAR TOP REFRACTORY PANEL	1
33	PL64601	REFRACTORY PANEL RETAINER	3
34	21363	REFRACTORY CERAMIC INSULATION 5 3/4" X 23"	9
35	21355	C-CAST FRONT BAFFLE 20 1/2" X 10 1/4" X 30 1/2"	1
36	PL64610	LEFT FRONT BAFFLE SUPPORT	1
37	PL64611	RIGHT FRONT BAFFLE SUPPORT	1
38	30126	METAL SCREW #10 X 1" QUADREX BLACK	8
39	21354	C-CAST REAR BAFFLE 14 3/4" X 5 45/64" X 16 31/32"	1
40	PL64613	LEFT OR RIGHT REAR BAFFLE SUPPORT	2
41	40013	BLACK 3/16" ROUND GASKET	3

VALCOURT LIMITED LIFETIME WARRANTY

The warranty of the manufacturer extends only to the original consumer purchaser and is not transferable. This warranty covers brand new products only, which have not been altered, modified nor repaired since shipment from factory. Products covered under this warranty must have been manufactured after the revision date indicated below. Proof of purchase (dated bill of sale), model name and serial number must be supplied when making any warranty claim to your VALCOURT dealer.

This warranty applies to normal residential use only. Damages caused by misuse, abuse, improper installation, lack of maintenance, over firing, negligence or accident during transportation, power failures, downdrafts, or venting problems are not covered by this warranty.

This warranty does not cover any scratch, corrosion, distortion, or discoloration. Any defect or damage caused by the use of unauthorized parts or others than original parts void this warranty. An authorized qualified technician must perform the installation in accordance with the instructions supplied with this product and all local and national building codes. Any service call related to an improper installation is not covered by this warranty.

The manufacturer may require that defective products be returned or that digital pictures be provided to support the claim. Returned products are to be shipped prepaid to the manufacturer for investigation. If a product is found to be defective, the manufacturer will repair or replace such defect. Transportation fees to ship the product back to the purchaser will be paid by the manufacturer. Repair work covered by the warranty, executed at the purchaser's domicile by an authorized qualified technician requires the prior approval of the manufacturer. Labour cost and repair work to the account of the manufacturer are based on predetermined rate schedule and must not exceed the wholesale price of the replacement part. All parts and labour costs covered by this warranty are limited according to the table below.

The manufacturer at its discretion may decide to repair or replace any part or unit after inspection and investigation of the defect. The manufacturer may, at its discretion, fully discharge all obligations with respect to this warranty by refunding the wholesale price of any warranted but defective parts. The manufacturer shall in no event be responsible for any special, indirect, consequential damages of any nature, which are in excess of the original purchase price of the product. A one-time replacement limit applies to all parts benefiting from a lifetime coverage. This warranty applies to products purchased after October 1st, 2011.

DESCRIPTION	WARRANTY APPLICATION	
	PARTS	LABOUR
Combustion chamber (welds only), castings, convector air-mate, ceramic glass (thermal breakage only*), and secondary air tubes*.	Lifetime	4 years
Plating* (defective manufacture) – subject to limitations above.	Lifetime	n/a
Stainless steel firebox components, surrounds and heat shields, ash drawer, steel legs, pedestal, trims (aluminum extrusions), C-Cast baffle*, and vermiculite baffle*.	5 years	3 years
Carbon steel firebox components, glass retainers, and handle assembly.	3 years	2 years
Blowers, heat sensors, switches, rheostat, wiring, and other controls.	2 years	1 year
Paint (peeling), gaskets, insulation, firebrick, and ceramic fibre blankets.	1 year	n/a

**Pictures required*

Shall your unit or a components be defective, contact immediately your **VALCOURT** dealer. Prior to your call make sure you have the following information necessary to your warranty claim treatment:

- Your name, address and telephone number;
- Serial number and model name as indicated on the nameplate fixed to the back of your unit;
- Bill of sale and dealer's name;
- Nature of the defect and any relevant information.

Before shipping your unit or defective component to our plant, you must obtain from your VALCOURT dealer an Authorization Number. Any merchandise shipped to our plant without authorization will be refused automatically and returned to sender.